

**EXPRESSION OF TENSE IN TSHIVENDA**<sup>^</sup>

BY

**MILINGONI JOYCE LIVHEBE**<sup>^</sup>

Research presented in partial fulfillment of the  
requirements for the degree of

Master of Arts

in the

Department of African Languages

in the

Faculty of Humanities

at the

University of the North

Promoter: Professor R.N. Madadzhe<sup>^</sup>

Date : January 2003



03/35599

**DECLARATION**

I the undersigned, hereby declare that EXPRESSION OF TENSE IN TSHIVENDA submitted to the University of the North is my original work, and that has not been submitted previously for a degree at any university.

.....

**M.J. LIVHEBE**  
^

.....

**DATE**

## DEDICATION

To the following people:

- My mother: Vho-Nyamukamadi Sinthumule
- My husband: Vho-Marubini Samson Livhebe
- My daughters: Mbavhalelo and Vhutshilo

## ACKNOWLEDGEMENTS

In Tshivenda there is a saying : “Munwe muthihi a u tusi mathuthu”. Indeed the work of this nature cannot be achieved by one man only without the assistance of others. Therefore I feel it is necessary to express my feelings of appreciation to the following people:

First of all, I would like to thank the almighty God for giving me strength and health to undertake this research successfully.

I would like to thank Professor R.N. Madadzhe for his support , guidance and unwaning patience during the course of this research study.I would also like to express my sincere thanks to Ms T.M. Matla who encouraged me and let me understand that I am capable of doing anything in life as long as I work hard and believe in myself.

My heartfelt gratitude goes to Dr T.K. Rankhododo who encouraged me to continue with my studies at Master’s level . Yes, it is true: “Mutuka wa haya ha vhihfi” I must also acknowledge the assistance and guidance given by Professor N.A. Milubi and Dr M.M. Sepota during the course of my studies.

I am also grateful to my mother Nyamukamadi Sinthumule for the support she gave me when things were difficult in my life. Many thanks are also directed to my brother Dzivhonele Albert Sinthumule. To him the following saying is relevant: “ Bebiwani ni ande”

It would be a great mistake if I forget to express my sincere thanks to my family: My husband Marubini Samson, and my daughters Mbavhalelo and Vhutshilo. Your patience, support and understanding have been acknowledged and appreciated during my research study.

Lastly my thanks are directed to my colleagues: Mrs Violet Radzilani, Mrs A.K. Makakavhule, Mrs C. Baloyi, Mrs M. Phungo, Mr M.F. Malimagovha , Mr Thenga and Mr T.G. Mamphwe. Their words of encouragement gave me strength to complete my studies. From them I learnt : “ Vhathu ndi mapfura vha a doliwa ”

## ABSTRACT

**Chapter 1** gives a general introduction to the study. It deals with the background to the problem, aim, rationale, significance, methodology and the layout. Different definitions on tense have been handled in this chapter.

**Chapter 2** discusses the present tense. The definition of the present tense, the usage of this tense and different semantic significances have been dealt with.

**Chapter 3** analyses the past tense . This chapter deals with the definition of the past tense, the morphological structure of the past tense and its meanings.

**Chapter 4** examines the future tense. The definition of the future tense is presented. It tries to ascertain whether the moods, verbs and the future tense are employed in Tshivenda. The study focuses on the structure and meaning of the future tense.

**Chapter 5** gives the conclusion of this research study . The findings and recommendations of the previous chapters haven been summarized.

<b>TABLE OF CONTENTS</b>	<b>PAGE</b>
(i) DECLARATION	i
(ii) DEDICATION	ii
(iii) ACKNOWLEDGE	iii
(iv) ABSTRACT	iv
<b>CHAPTER 1</b>	<b>1</b>
<b>CHAPTER 1: GENERAL INTRODUCTION</b>	<b>1</b>
1. INTRODUCTION	1
2. ORIENTATION AND BACKGROUND TO THE PROBLEM	2
3. LITERATURE REVIEW	3
4. RESEARCH HYPOTHESIS	8
5. AIMS AND OBJECTIVES OF THE RESEARCH STUDY	8
6. RATIONALE OF THE STUDY	8
7. SIGNIFICANCE	8
8. RESEARCH METHODOLOGY	9
8.1. DESIGN	9
8.2. DATA COLLECTION TECHNIQUES	9
9. DEFINITION OF CONCEPTS	10
9.1. TENSE	10
9.2. AGREEMENT MORPHEMES	12
9.3. NEGATIVES	14
9.4. INTRANSITIVE VERBS	15
9.5. TRANSITIVE VERBS	15
9.6. DITRANSITIVE	17
9.7. ARGUMENTS	18
9.8. SITUATIVE VERBS	19
9.9. INTERROGATIVES	20
9.10. SUBJECT INVERSION	21
10. ORGANISATION OF THE STUDY	21

<b>CHAPTER 2 : THE PRESENT TENSE</b>	<b>23</b>
1. INTRODUCTION	23
2. DEFINITION OF THE PRESENT TENSE	23
3. THE MORPHOLOGICAL STRUCTURE OF THE PRESENT TENSE	23
3.1. THE SHORT FORM	24
3.2. THE LONG FORM	30
4. THE SEMANTIC SIGNIFICANCE OF THE PRESENT TENSE	36
4.1. TEMPORAL SPECIFICATION	37
4.2. HABITUAL ACTION	39
4.3. EMPHASIS	39
4.4. ONGOING ACTION	40
5. CONCLUSION	41
<b>CHAPTER 3 : THE PAST TENSE</b>	<b>42</b>
1. INTRODUCTION	42
2. DEFINITION OF THE PAST TENSE	42
3. THE MORPHOLOGICAL STRUCTURE OF THE PAST TENSE	43
3.1. INTRANSITIVE VERBS	46
3.2. TRANSITIVE VERBS	47
3.3. TRANSITIVE VERBS WITH [ AGRO ]	48
3.4. DITRANSITIVE VERBS	49
3.5. DITRANSITIVE VERBS WITH [ AGRO ]	49
3.6. TEMPORAL SPECIFIERS	50
3.7. INFINITIVE	51
3.8. URI- CLAUSE	51
3.9. INTERROGATIVE	51
3.10. PARTICIPIAL CLAUSE	52
3.11. NEGATIVE	52
3.12. COPULATIVE	54
4. THE SEMANTIC SIGNIFICANCE OF THE PAST TENSE	54
4.1. PAST TENSE	55
4.2. PRESENT TENSE	55
4.3. EMPHASIS	56

4.4. RECENT PAST	56
4.5. REMOTE PAST	57
4.6. SEMANTIC VERB ROOTS	57
5.CONCLUSION	59
<b>CHAPTER 4 : THE FUTURE TENSE</b>	<b>61</b>
1. INTRODUCTION	61
2. DEFINITION OF THE FUTURE TENSE	61
3. THE MORPHOLOGICAL STRUCTURE OF THE FUTURE TENSE	62
3.1. THE PARTICIPIAL	62
3.2. THE POTENTIAL	63
3.3. COPULATIVE	64
3.4. THE CONSECUTIVE	64
3.5. URI- CLAUSE ( SUBJUNCTIVE )	66
3.6. LOCATIVE	67
3.7. RELATIVE WITH THE RELATIVE MARKER [ -HO ]	67
3.8. INTERROGATIVE	68
3.9. INTRANSITIVES	68
3.10. TRANSITIVE	69
3.11. TRANSITIVE WITH [ AGRO]	69
3.12. NEGATIVE	70
3.13. INVERSION	70
4. SEMANTIC SIGNIFICANCE OF THE FUTURE TENSE	71
4.1. SIMPLE PRESENT TENSE	71
4.2. FUTURE AND HABITUAL ACTION	72
4.3. STATUS	73
4.4. VOLITION, WILINGNESS , OR INTENTION	73
4.5. CONDITION, TIME AND PURPOSE	75
4.6. PREDICTION	76
4.7. EMPHASIS	76
4.8. WITH OR WITHOUT A TIME EXPRESSION	76
4.9. STATIVE ROOTS	77
4.10. INCHOATIVE ROOTS	77
4.11. ACTIONAL ROOTS	78
5. CONCLUSION	78



<b>CHAPTER 5 : CONCLUSION AND RECOMMENDATIONS</b>	<b>79</b>
1. CONCLUSION	79
2. RECOMMENDATIONS	85
REFERENCES	86

## CHAPTER 1

### EXPRESSION OF TENSE IN TSHIVENDA ^

#### 1. INTRODUCTION

Communication in the universe is mainly based on languages. Communication is a means through which people exchange feelings and ideas with one another. Language is thus used as one of the tools or vehicles in a communication process.

When people communicate, they are bound to employ a variety of tenses.

(1). **Ndi** ya tshikolo.  
( I go to school ).

(2). **Ndo** ya tshikoloni.  
( I went to school ).

(3). Ndi **do** ya tshikoloni.  
( I will go to school ).

The above three sentences (1-3 ) reflect types of tense, namely the present, the past and the future tense respectively. From the same examples, it is evident that tense goes hand in hand with time. This view is supported by Barnes et al. (1967:75) definition of tense:

Time expressed by the verb is called tense. Tenses are therefore the different forms of the verb by which time is expressed.

Moreover, tense and action are interwoven. In this regard, Barnes et al. (1967:75) of the relationship between time and action is apt:

Tense is any of the forms of the verb that indicates time of action or state expressed by the verb.

When one talks about the time of action one is not considering the time stated in hours and minutes of the day excluding tenses. Tense refers to the time of occurrence of action, state, or events.

It is therefore vital that the speaker and the listener should know about this interaction. Otherwise, misunderstanding and conflict may result between the speaker and the listener. An in-depth understanding of tense is therefore critical in bringing about sound relations between the speaker and the audience.

## 2. ORIENTATION AND BACKGROUND TO THE PROBLEM

Tense as a morphological phenomenon has not received much scrutiny in Tshivenda. Few literature (Milubi, 1996; Du Plessis and Madadzhe, 1999) focus on the fact that there are three tense forms in Tshivenda, namely, the present, the past and the future tense. What these tenses really mean has not as yet been satisfactorily explored.

Another issue that crops up regularly is the belief that agreement plays a role in the formation of tense. This seems to be an erroneous assertion because tense is an independent morphological category. In simple words, tense's existence is not contingent on other categories.

Although tense is a morphological category in its own right, its significance becomes prominent when other categories are also treated hand in hand with it. In this regard the following categories are worth mentioning: subjectival agreement, objectival agreement, moods, transitive verbs, locatives, negation, etc. Important as these categories may be, they hardly receive attention in Tshivenda literature. Hence, it is necessary to conduct a study where some of these issues will be scrutinized.

Currently in Tshivenda there seems to be a lot of confusion as regards the meanings expressed by a variety of tenses. For instance, the past tense is generally regarded as a tense denotes an action that has already occurred. While this may be correct, it is however not always so. Consider the following example:

(4). Ndo neta.

( I am tired ).

The above sentence is morphologically in the past tense but it expresses the meaning of an action that is currently happening.

The aforementioned exposition conforms the view that tense in Tshivenda is a complex subject that needs serious study such as this one.

### 3. LITERATURE REVIEW

Tense as a grammatical phenomenon has already been studied by various scholars. As far as Tshivenda is concerned, the studies concentrated on the morphological characteristics of tense. Issues such as the context, the semantic and the syntactic features hardly got any scrutiny. What other scholars have already written about tense cannot, however, be ignored and will have to be utilized as a basis from which new research should be launched. Bell (1993:19) concurs with this strategy when he states:

Critical review should show that the writer has studied existing work in the field with insight.

Milubi's (1996:102-104) focuses on the types of tenses that occur in Tshivenda, namely the present, past and future tense. Milubi does not give an exact definition of tense, he only gives the basic types of tenses, viz, the present, future and past tenses. His study is nevertheless of great significance as it shows that there is a relationship between action and tense in Tshivenda. Ample examples in this regard have been provided. For instance:

(5). Ndi khou tshimbila.  
( I am walking ).

According to Milubi (1996:103) the above sentence is in the present continuous tense because the auxiliary verb **khou** indicates continuous action. Like Milubi, Du Plessies and Madadzhe (1999:137) do not define tense. Their analysis focuses on tense as the maximal projection of the phrase (TP) where the tense (T) is the head of the tense phrase (TP).

Du Plessis and Madadzhe treat many aspects with which tense appears. They state that the present tense can appear with the morpheme <sup>^</sup>-a- and without <sup>^</sup>-a- to indicate the long and short forms respectively:

(6) (a) Zwinoni zwi a fhufha.

( Birds fly ).

(b) Zwinoni zwi fhufha dakani.

( Birds fly in the forest ).

Sentence 6 (a) is the long form while sentence 6 (b) is the short form of the present tense. In this case, one discerns that the short form of the present tense 6 (b) appears with a locative for it to become acceptable or grammatical while sentence 6 (a) is acceptable as it is ( without a locative ). The reasons for this state of affairs have not been discussed or advanced by the said scholars. It will therefore be important to find out why Tshivenda behaves in this fashion.

Another important aspect in their ( Du Plessis and Madadzhe ) analysis is the contention that the perfect tense is distinguished by <sup>^</sup>the appearance of the morpheme -o:

(7). Vhathu vho <sup>^</sup>la vhurotho.

( People ate bread ).

Whilst the above thesis is true in some instances, it does not, however, hold water in other instances:

(8).(a) Vhathu vhane vha <sup>^</sup>la vhurotho.

( People who eat bread ).

(b) Vhathu vhe vha <sup>^</sup>la vhurotho.

( People who ate bread ).

Sentences 8 (a) and 8 (b) are in the present and past tenses respectively, yet sentence (b) does not reflect the morpheme -o to indicate the past, but uses e instead. This can be illustrated as follows:

**Agreement + Tense Marker**

Vha + -ne ( present)

**Agreement + Tense Marker**

Vha + -e (past)

Du Plessis and Madadzhe's study is, nonetheless, a worthwhile one as it also treats a variety of meanings expressed by various tenses.

Tenses have also been analysed in some detail by Ziervogel et al. (1972:06), but they, too, do not give a definition of tense and its uses in various contexts. They indicate that tense can occur in three forms and explain that the present tense can occur in the short and long forms and in the continuous and progressive structures. Hereunder are a few examples that they employ to illustrate their point of view:

**The short present tense:**

(9). Ndi vhona.

( I see ).

**The long present tense:**

(10). Ndi a vhona.

( I see ).

**The continuous present tense:**

(11). Ndi khou vhona.

( I am seeing ).

**The progressive present tense:**

(12). Ndi kha di vhona.

( I am still seeing ).

Although Ziervogel et al's study may be regarded as having contributed along towards our understanding of tense in Tshivenda, it is inadequate. This is so because various meanings that are expressed by tense have not been handled at all.

Poulos (1990:249) does not define tense, but does show the interaction between tense and verbs. Moreover, unlike Milubi (1996), Du Plessis and Madadzhe (1999) and Ziervogel et al.(1972) who categorises tense into three forms ( present, future and past ), Poulos argue that there are four basic tenses in Tshivenda:

**The present tense:**

(13). U a amba.  
( He / speaks ).

**The present continuous tense:**

(14). U khou amba.  
( He / She is speaking ).

**The future tense:**

(15). Ndi do amba.  
( I shall speak ).

**The perfect tense:**

(16). Vho amba.  
( They have spoken).

As there are two divergent views ( i.e. one view states that there are three types of tense while the other view contends that there are four types of tense in Tshivenda as regards the number of tenses in Tshivenda, this study will be compelled to scrutinize them and ultimately come up with an acceptable thesis.

According to Klein (1992), tense is any of the forms of a verb which show the time at which an action happened. Klein focuses on the fact that besides tense temporal adverbials can indicate tense. Temporal adverbials have various functions and hereunder are some of them:

- They specify the time span as the time axis ( e.g. then, yesterday, two weeks ago)
- They specify the duration ( e.g. for two days)
- They specify the frequency of time spans ( e.g. twice , most often , regularly)

Madadzhe's analysis of tense (1997 :114) echoes that of Ziervogel et al. (1990) and Klein (1992). He argues that tense is used in syntax to indicate the time at which the action denoted by a verb takes place. A captivating feature in Madadzhe's analysis is when he mentions that although tense is a common category in the languages of the world, it is however not universal as there are some languages that do not utilise it at all, e.g. Chinese. Tshivenda is one of the languages that use tense, but even in this case infinitives and the imperative are not marked by tense.

Like Milubi (1996), Du Plessis and Madadzhe (1999), Ziervogel et al. (1972), Madadzhe (1997) is also of the same opinion that three types of tenses are distinguished in Tshivenda, namely, the present, the future and the perfect tense.

Although Madadzhe's study on tense in Tshivenda is a fascinating one, it does not however, like most of the scholars already referred to in the aforementioned discussion, delve into the semantic functions of tense.

Like the rest of the scholars already cited, Lyons (1977:386) regards tense as a morphological category. Lyons's emphasis is however, rather than being on the morphological features of tense, on semantic functions with which tense is associated. In this regard, the following semantic functions are pertinent:

- Possibility
- Prediction
- Intention
- Desire
- Supposition, etc

As it seems that the above- mentioned functions have not as yet been examined in Tshivenda, it will therefore be worthwhile to determine whether they also apply to Tshivenda.



#### 4. RESEARCH HYPOTHESES

The research is conducted to validate the following hypotheses:

- Tense forms an intergral part of Tshivenda grammar and discourse.
- Tense leads to ambiquity and misunderstanding if not handled satisfactorily

#### 5. AIM AND OBJECTIVES OF THE RESEARCH STUDY

The main aim of this research study is to examine THE EXPRESSION OF TENSE IN TSHIVENDA. In order to achieve this aim, the following questions will have to be tackled:

- How many types of tense occur in Tshivenda?
- Which meanings are associated with tense in Tshivenda?
- What are the implications of improper use of tense in Tshivenda?
- What does the presence or absence of agreement morphemes in Tshivenda sentences signify in regard to tense?
- What is the role of context in determining tense in Tshivenda?

#### 6. RATIONALE OF THE STUDY

The research is going to add more knowledge and provides new insights into the semantic, morphological and syntactic features of tense in Tshivenda.

#### 7. SIGNIFICANCE

Given the paucity of research on Tshivenda tense, the envisaged study is an endeavour to contribute to our understanding in this field. Moreover, it will serve as a source of information for researchers interested in Tshivenda grammar in general and Tshivenda tense in particular.

The study will show that tense is not studied for its own sake, but for various reasons, amongst others:

- Tense is an indispensable part of everyday discourse.
- Wrong usage of tense may lead to ambiguity, misunderstanding and even conflict.
- Although some aspects of tense formation and usage may be applied universally, the study will make an incisive analysis in showing that there are other areas where this thesis is not applicable.
- Many curriculum designers and Tshivenda teachers assume that tense is of less significance than other grammatical categories as a topic to study. This study will attempt to dispel the said notion.

## **8. RESEARCH METHODOLOGY**

### **8.1. DESIGN**

The qualitative method will be utilized in this research. Gay (1996: 208) states that this method is of great significance as it involves the collection and analysis of data in order to gain insights into a situation, which would not be possible using other types of research. In a study of this nature, the qualitative method is indispensable as it facilitate the developmental process of investigation. This method will also help the researcher not to be bound by preconceived ideas as reflected in published materials.

### **8.2. DATA COLLECTION TECHNIQUES**

The following data collection techniques will be used:

#### **8.2.1. Primary Research Method**

Primary research method is the method whereby first- hand information is obtained from respondents. Research will be undertaken through consultation with experts in grammar such as lecturers, authors and teachers.

#### **8.2.2. Secondary Research Method.**

Secondary research method is of importance in this study as more information will be gathered from different sources such as library books, articles, published and unpublished dissertations.

## 9. DEFINITION OF CONCEPTS

In this section concepts that have been used in the study will be described. The section will concentrate on those concepts that form an integral part of the study.

### 9.1. TENSE.

Tense is regarded as an aspect which indicates the time of action, events or state, i.e. when does an action happen? When did it happen? When will it happen?

(17). Mpho u tamba bola.  
( Mpho plays the ball ).

Sentence (17) denotes that the action takes place now, in present time . The tense is the Present Tense.

(18). Mpho o tamba bola.  
( Mpho played the ball ).

Sentence (18) indicates that the action took place sometimes ago, yesterday, long ago, or in the past time. The tense is called the Past Tense.

(19). Mpho u do tamba bola.  
(Mpho will play the ball ).

Sentence (19) shows that the action will take place in the future, either tomorrow or the next time . The tense is known as the Future Tense . The following definitions of tense support what has been discussed in (17-19) above.

Huddleston (1984:80-81) gives the general definition of tense thus:

It applies to a system of the verb and / or VP, with terms differentiated inflectionally or by means of auxiliaries where the primary semantic contrast has to do with location in time especially location relative to the time of

speaking. For example , in **He took the bus to work** I am talking about an event or situation located in the past, i.e. a period preceding the time of my utterance, whereas in **He takes the bus to work** the situation occupies a period of time that includes the moment of speaking.

Elsness (1997:15 ) defines tense as follows:

The word tense is derived from Latin tempus, which is a translation of the Greek word for "time" χρόνος. The etymological origin of the term points to one of its essential characteristics: while a large number of different definitions have been suggested, there is general agreement that the linguistic category of tense is somehow related to the universal, language- independent concept of time.

A more embracing definition of tense is given by Lyons (1977:678) when he contends:

Tense, in those languages which have tense, is part of the deictic frame of temporal reference: it grammaticalizes the relationship which holds between the time of the situation that is being described and the temporal zero-point of the deictic context.

Tense is a problematic aspect of language. This point is emphasized by Lyons (1981 : 159) when he says:

As for tense, it is significant that no one has yet succeeded in giving a satisfactory account of the meaning of the tenses ( traditionally identified by means of such terms as "past", "present" , "future") in English or any well- studied language.

In spite of the reservations indicated by Lyons, tense in Tshivenda needs to be examined in one way or another.

## 9.2. AGREEMENT MORPHEMES.

Agreement morphemes in Tshivenda are divided into two types: subjectiv agreement and objective agreement.

Agreement morphemes are what is traditionally called concordial morphemes. Poulos (1990: 5 & 221) defines them as follows:

Concordial agreement is meant that those categories in the language which have some or other bearing on, or which are grammatically related to the noun, show agreement with the class of the noun by using concord of that class . An object concord is that element of the verb that shows agreement with the object noun.

### 1. Subjectival Agreement [ AGRS ]

The subject agreement [ AGRS] is the head of the subject agreement phrase [ AGRSP] . The subject agreement substitutes or works in agreement with the subject noun [ NP ] or external argument.

(20).Musidzana **u** <sup>◌</sup>nwala vhurifhi.  
(The girl writes a letter.)

The [ AGRS ] **u** is the head of the [ AGRSP] and works in agreement with the subject noun **musidzana** in the present tense.

### 2. Objectival Agreement [ AGRO]

The object agreement replaces or agrees with the object noun [ NP] or internal argument. The object agreement [ AGRO] is the head of the [ AGROP]:

(21) Musidzana u a vhu <sup>◌</sup>nwala vhurifhi.  
\* ( The girl writes it a letter )

From the above sentence (21) **vhu** the object agreement works in agreement with the object noun **vhurifhi** in the present tense.

The table of the agreement morphemes is given underneath in order to show tense in different forms.

(8)

Noun Class	Noun Prefix	Subject Agreement		Object Agreement	
		Present Tense	Past tense	Present Tense	Past Tense
1 <sup>st</sup> Singular		Ndi	Ndo	n-	Ndo
1 <sup>st</sup> Plurals		Ri	Ro	ri	Ro
2 <sup>nd</sup> Singular		U	Wo	u	Wo
2 <sup>nd</sup> Plurals		ni	no	ni	no
1	Mu-	U	O	Mu	O
2	Vha-	Vha	Vho	Vha	Vho
3	Mu-	U	Wo	U	Wo
4	Mi-	I	Yo	I	Yo
5	Li- ^	Li ^	Lo ^	Li ^	Lo
6	Ma-	A	O	A	O
7	Tshi-	Tshi	Tsho	Tshi	Tsho
8	Zwi-	Zwi	Zwo	Zwi	Zwo
9	N-	I	Yo	I	Yo
10	Dzi-	Dzi	Dzo	Dzi	Dzo
11	Lu-	Lu	Lwo	Lu	Ho
14	Vhu-	Vhu	Ho	Vhu	Ho
15	U-	Hu	Ho	Hu	Ho
16	Fha-	Hu	Ho	Hu	Ho
17	Ku-	Hu	Ho	Hu	Ho
18	Mu-	Hu	Ho	Hu	Ho
20	Ku-	Ku	Kwo	Ku	Kwo
21	Di- ^	Li ^	Lo ^	Li ^	Lo ^

### 9.3. NEGATIVES.

The lexical head of negative phrase [ NEGP ] is the negative [ NEG ] . The negative in Tshivenda is formed by affixing the negative morphemes such as **a**, **si**, **sa**, **ha**, **nga**, **ngo** and **songo** to the verb phrase. The negative morphemes can be inserted in different tenses in order to transform the positive structures to the negative structures.

It is important to state that tense and the negative are not the only inflectional categories in Tshivenda. There are other inflectional categories with which they appear and these may be summarized as follows:

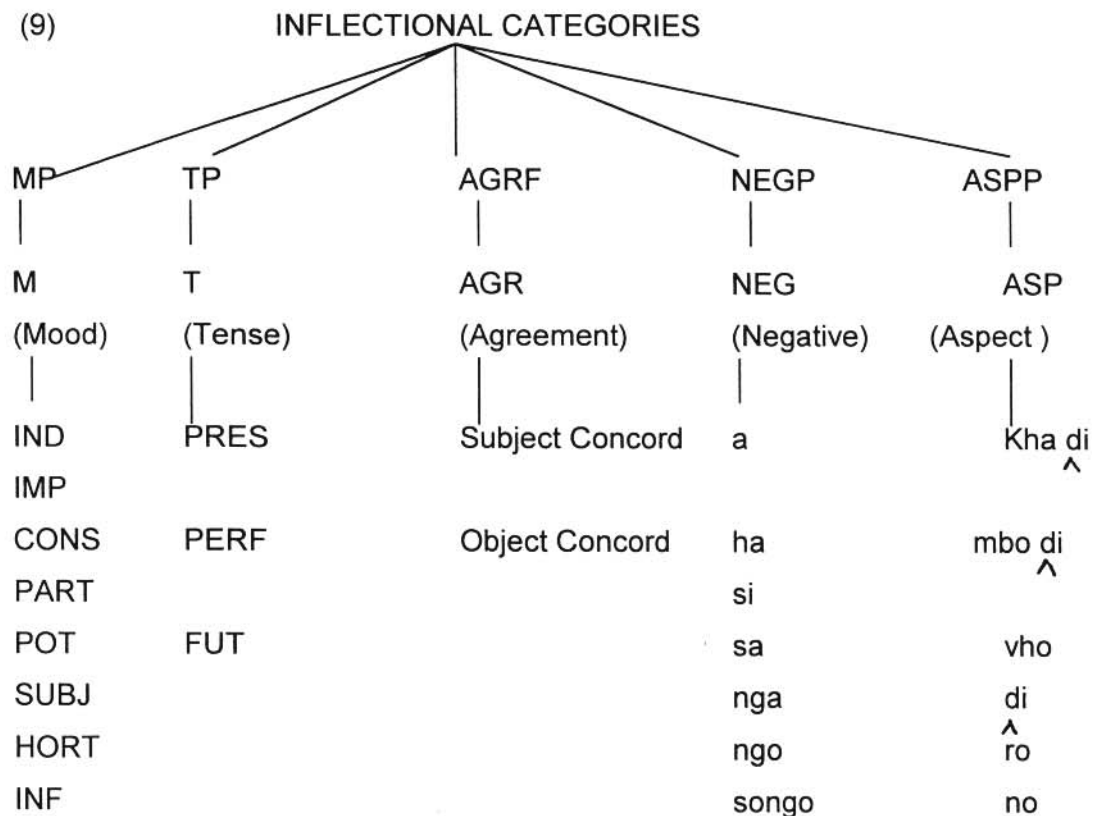

An example of a sentence in which the above mentioned categories appear is as follows:

- (22). A vha tsha <sup>•</sup>nwala.  
 (They no longer write.)

Mood [ M] - indicative mood

Tense [ T]	-	present tense
Agreement [ AGR]	-	+2
Negative [NEG ]	-	a
Aspect [ ASP]	-	tsha

#### 9.4. INTRANSITIVE VERBS.

Intransitive verbs are verbs that do not take a direct object. These verbs may contain the indirect internal argument, and external argument and the locative argument:

(23) (a) Mutukana u a <sup>^</sup>la.  
( The boy is eating. )

(b) Vhana vha tamba mudavhini.  
( The children in the playground.)

The NPs **mutukana** and **vhana** are the external arguments in the subject position. The intransitive verbs **la** and **tamba** assign the external argument in the present tense. The NP **mudavhini** is the location argument.

Du Plessis and Visser ( 1996:21 ) expand on this type of tense as follows:

The argument structure of intransitive verb can be approached in two different ways depending on the list of arguments. On the one hand intransitive verb may be distinguished through the logical notion that an intransitive predicate is regarded as a one place predicate such predicate assign only on theta-role to a linguistic expression called an argument. The argument structure of this predicate thus show one argument which has to appear as a subject argument.

#### 9.5. TRANSITIVE VERBS.

Transitive verbs are used with a direct object:



(24) (a) Mufumakadzi u bika vhuswa.

( The lady cooks porridge. )

(b) Vhatukana vha vhala bugu.

(The boys read the book.)

In sentences 24 (a - b), **mufumakadzi** and **vhatukana** are the external arguments in the subject position. **Vhuswa** and **bugu** are the direct internal arguments in the object position. The transitive verbs **bika** and **vhala** assign two  $\theta$  -roles, the one to the subject external argument and the second to the internal argument. The above description supports Du Plessis and Visser's (1996:29) definition of transitive verbs:

Transitive verbs are to be regarded as two-place predicates. Their predicate argument structure thus allows two arguments where the one argument is an external argument and the second one an internal argument. According to the theta - theory, transitive verbs have two theta- roles, the one theta-roles is to be found in the subject position and the other one in the object position of the verb.

Using the above definition as a premise, the following sentence can be used for illustrative purposes:

(25). Tendani u **renga** vhurotho.

(Tendani buys the bread.)

**Renga** in the above example is a transitive verb as it appears with an object argument, namely, **vhurotho**. **Tendani** is the agent ( the external argument) in the subject position carrying over the action **u renga** to the patient **vhurotho** in the present tense

Hopper et al. (1982:211-213) also give two types of transitivity – structural transitivity and traditional transitivity:

Structural transitivity is defined as the structure relationship a predicate and two monoblique

arguments, a subject and direct object, at a specifiable level. Traditional transitivity is defined globally over an entire clause, referring to the carrying over or transferring of an action from the agent to the patient.

## 9.6. DITRANSITIVE.

Ditransitive verbs are verbs which take two direct objects -

Du Plessis and Visser ( 1996:41 ) describe ditransitive verbs as follows:

Ditransitive verbs appear in predicates which have two internal arguments.

A more comprehensive definition of ditransitive verbs is given by Hopper, et al (1982 : 264) who state:

Ditransitive verbs require two direct objects, unless ellipsis has taken place. One might suggest that with ditransitive verbs it is the indirect, and only the indirect object that gets indexed in the verb ( the indirect object being the NP that encodes the participant to whom something is given, shown etc). It is evident that with ditransitive verbs it is the direct object which bears a goal relation (i.e. the participant to whom something is given, shown, etc)

The following sentence shows an example of a ditransitive verb:

- (26). Munna u **fha** <sup>o</sup> **nwana** tshelede.  
( The man gives the child money. )

In the above sentence, **fha** appears as the ditransitive verb. **Fha** occurs with two object NP<sub>s</sub>, i.e. **nwana** and **tshelede**. **Fha** as such assigns two theta roles to the said objects. **Nwana** is assigned the theta role of recipient while **tshelede** is assigned the theta role of theme.

## 9.7. ARGUMENTS.

Arguments are the nouns used in the sentences. Subject nouns can be used in the subject predicate clauses and object nouns can be found in the object predicate clauses.

Cook and Newson, (1996:160) show the arguments in relation with the predicate as follows:

A predicate expresses the meaning relationship between arguments the meaning relationship between the predicate and the arguments knowing how many arguments are related by a predicate is part of knowing what the predicate means.

An example below, serves to show the relationship between the arguments and the predicate:

- (27) (a) Munna u fha n̄wana malegere tshikoloni.  
 (The man gives the child sweets at school).

(b)

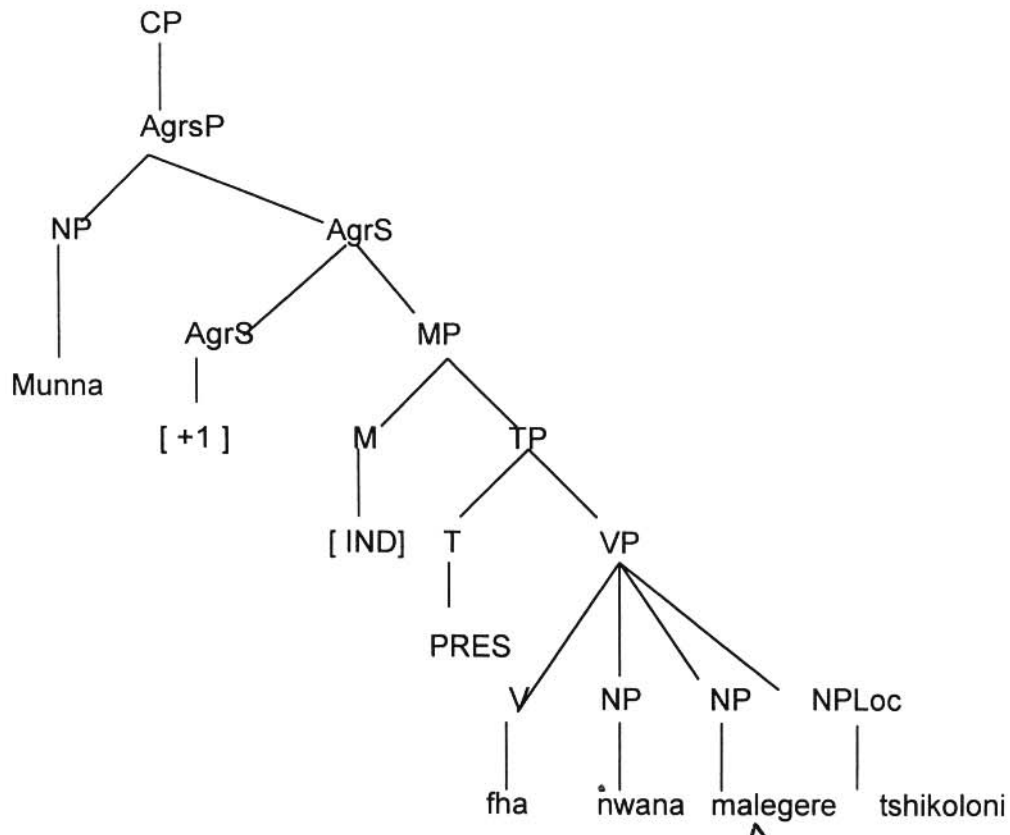

The NP **munna** is the subject argument, therefore **munna** is the external argument assigned the agent  $\theta$ -role by the verb **fha**. The NP<sub>s</sub> **nwana**, **malegere** and **tshikoloni** are the object arguments. **Nwana** is the direct internal argument assigned the benefactive theta-role, **malegere** is the indirect internal argument assigned the theme theta-role and **tshikoloni** is the internal locative argument assigned the locative theta-role by the verb **fha**. The verb **fha** employed in the above sentence assigns the arguments four theta-roles in the present tense.

### 9.8. SITUATIVE VERBS

The situative verb is an independent element modifying the predicate. The situative verb indicates the situation where two actions take place simultaneously:

- (28). **Nwana** u tshimbila a tshi lila.  
 (The child works while crying)

Sentence (28) shows that the walking and the crying occur simultaneously. The situative verb contains a distinctive morpheme **tshi** and can occur in two tenses, the present and the future tense. Du Plessis and Madadzhe (1999: 85) point out:

Verbs appear with the morpheme **tshi** in the present and future tense. The **tshi** infact replaces the long form **a** of the indicative.

Ziervogel et al. (1972 :91) also refer to the participial ( situative) mood as follows:

The participial mood is used to express simultaneous actions consequently it is a dependent form in the sense that it must be used together with another predicate.

### 9.9. INTERROGATIVES

Interrogative is to change the plain predicate clause into the form of questioning. Question words, interrogative affixes and tone are employed to change the predicate clause into the interrogative clause.

Interrogatives may appear in the following forms:

### 1. Question Words.

Question words such as **naa?** **nnyi?** **ngafhi?** **lini?** **hani?** etc., may be used to change predicate clauses into interrogatives.

(29). (a) **Naa** ni khou vhala?

( Are you reading ?)

(b) Vhasidzana vha khou tshina **naa?**

(Are the girls dancing ?)

( c). Ndi **nnyi** ane a khou lila?

( Who is crying ?)

### 1. Interrogative Affixes

**-ni?** **-de ?** **- ifhio?** etc., are some of the interrogative affixes that help a lot in changing predicates into interrogative clauses.

(30) (a) **Ndi mini** tshine tsha vhila? **-ni?**

( What is boiling ?)

(b) Ndi **n̄wana** **ufhio ? -fhio?**

( Which child is it ? )

### 2. Tone

Tone can be noticed clearly in verbal language. The question marks can be amounted at the end of the predicate clauses when changing the plain predicate into the interrogative clause in writing, for example:

(31).(a) Ni khou **n̄wala?**

( Are you writing ?)

- (b) No fhedza u bika?  
( Have you finish cooking ? )

### 9.10. SUBJECT INVERSION

Subject inversion is when the subject occupies the adjunct position next to the verb and ends up receiving focus:

- (32) (a) (i). Vhadededzi vha a imba  
( The teachers are singing )

- ( ii). Hu imba vhadededzi  
( There sing teachers )

- (b) (i). Vhagudiswa vha a <sup>o</sup>nwala  
(The learners are writing )

- ( ii). Hu <sup>o</sup>nwala vhagudiswa  
( There write the learners )

## 10. ORGANISATION OF THE STUDY

**Chapter 1** is an introductory chapter . The background to the problem, literature review, hypothesis, aim, rationale, significance, methodology and the layout of the study are included in the discussion. The definitions of various concepts are given.

**Chapter 2** deals with the present tense. The definition of the present tense is given. An attempt has been made to indicate how the present tense is formed. Various meanings that are associated with the present tense have been examined.

**Chapter 3** deals with the past tense. The structure and meanings of the past tense have been analysed.

**Chapter 4** examines the application of the future tense in Tshivenda. The definition

of the future tense is presented. Various moods, verbs and the usage of the future tense have been scrutinized. The investigation focuses more on the structure and meaning of the future tense.

**Chapter 5** is a concluding chapter. It summarises the findings of the research study and outlines the recommendations thereafter.

## CHAPTER 2

### THE PRESENT TENSE

#### 1. INTRODUCTION

The aim of this chapter is to examine the present tense in Tshivenda. The aim will be achieved by looking at the following issues or aspects: definition of the present tense, the morphological structure and the semantic significance of the present tense.

#### 2. DEFINITION OF THE PRESENT TENSE

The present tense expresses what is happening at the moment of utterance. It might be confused with the past tense because it expresses the action which takes place a minute before the speaker speaks or expresses habitual action or actions as executed by the subject:

- (1) Musidzana u vhala bugu.  
( The girl reads the book. )

The action in sentence (1) takes place "now" i.e. at the moment of speaking or expresses the girl's ( musidzana ) habit of reading.

#### 3. THE MORPHOLOGICAL STRUCTURE OF THE PRESENT TENSE

In Tshivenda the present tense has two forms: the short and long forms. In this regard Poulos ( 1990 : 254 ) indicates:

The long form has the characteristics vowel  
a in it , while the short form lacks this vowel.



### 3.1.THE SHORT FORM

This form is short and has no distinctive morpheme which distinguishes it from the long form. The short form sentences can be determined by different kinds of verbs in the predicate clauses and arguments in the subject and object positions.

#### 1. Intransitive Verbs

- (2) Mulalo u tamba tshikoloni.  
( Mulalo plays at school.)

Sentence ( 2) is formed by the intransitive verb **tamba** which appears with the subject agreement **u** and it precedes the locative argument **tshikoloni** . The verb in a tree diagram will be represented as follows:

(3)

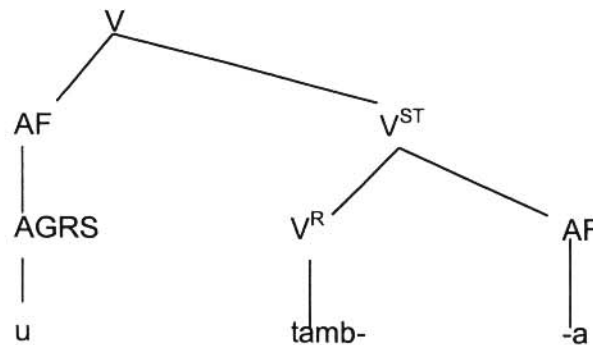

[AGRS – V – a ]

#### 2. Transitive Verbs.

- (4) (a) Mulalo u tamba bola.  
( Mulalo plays the ball. )
- (b) Kholomo dzi fula hatsi.  
( The cattle graze grass. )

Sentences 4 ( a-b ) denote the present tense in the short form. The transitive verbs are made up of subject agreement morphemes ( **u, dzi** ) preceding the verb roots

**tamb-** and **ful-** and the terminating vowel **-a**. The morphological structure of these verbs will be represented thus:

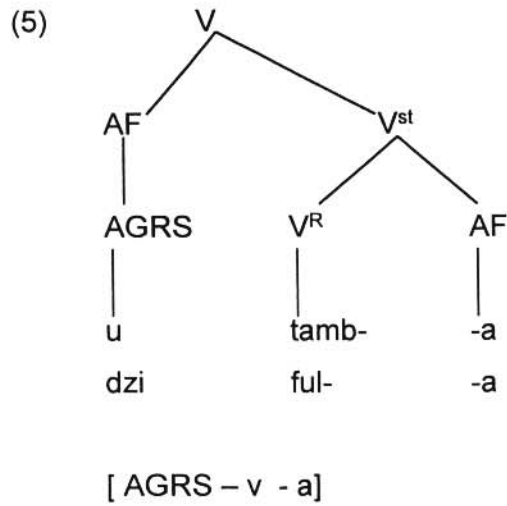

### 3. Ditransitive Verbs.

(6) (a) Vha shela miroho manyoro.  
( They pour the vegetables manure.)

(b) Mutukana u shelela mbudzi madi.  
( The boy pours water for the goats).

The ditransitive verbs **shela** and **shelela** denote the short present tense in 6 ( a - b ). These sentences are characterized by the AGRS ( **vha, u** ) and the verb roots **shelel-** followed by the ending vowel **-a**. The morphological structure of the verbs in 6 ( a - b ) will be represented as follows:

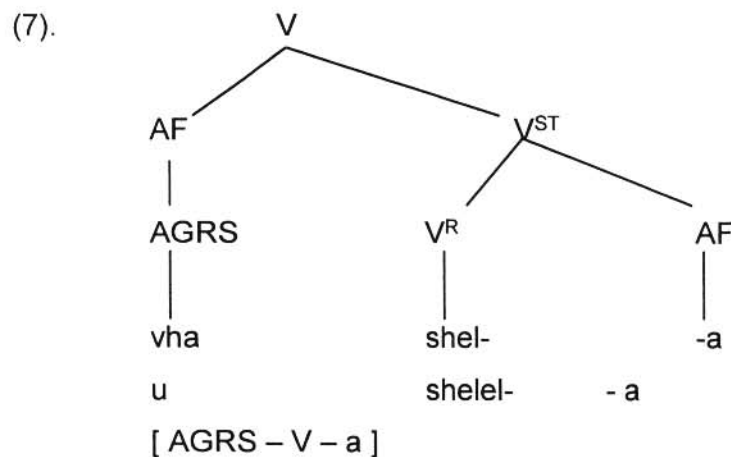

#### 4. Ditransitive verbs with [ AGRO ]

(8) (a) Vha i shela ( miroho) manyoro.

\* ( They pour them ( vegetables ) manure. )

(b) Mutukana u dzi shelela ( mbudzi) madi.

\* ( The boy pours water for them ( goats) )

The ditransitive verbs (**shela, shelela**) denote the short present tense accompanied by the object agreement morphemes (i , dzi) in sentences 8 (a - b ). The morphological structure of the ditransitive verbs appearing with [ AGRO] will be as shown below:

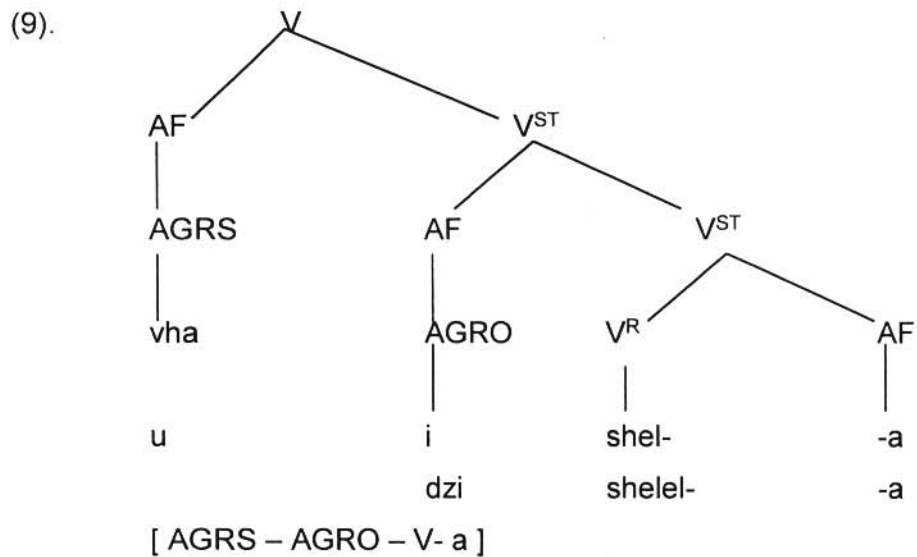

#### 5.Situative Verbs

10. (a) Nwana u tshimbila a tshi lila.

( The child walks while crying. )

(b) Vha shuma vha tshi tamba.

(They work while playing.)

The situative verbs cannot appear in the short form. The situative predicate clauses [ **a tshi lila, vha tshi tamba** ] take the present long form tense as indicated by Du Plessis and Madadzhe ( 1999: 85 ):

Verbs appear with the morpheme **tshi** in the present and future tenses. The **tshi** in fact replaces the long form **a** of indicative.

Sentences 10 ( a - b ) are made up of subject agreements ( **u , vha** ) and the situative morpheme **tshi** followed by the verb roots ( **lil - , tamb-** ) and terminating vowel **-a** . The morphological structure of the situative verbs will be represented as follows:

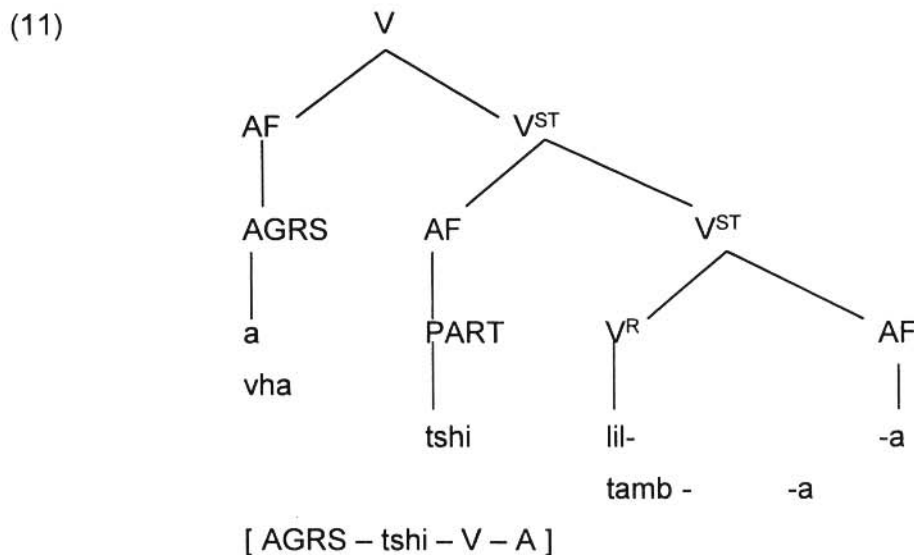

## 6. Interrogatives

(12) (a) Vha dzula ngafhi ?  
( Where does he / she lives ? )

(b) Hu lila nnyi?  
( Who is crying ? )

(c) Ni n̄wala mini ?  
( What do you write ? )

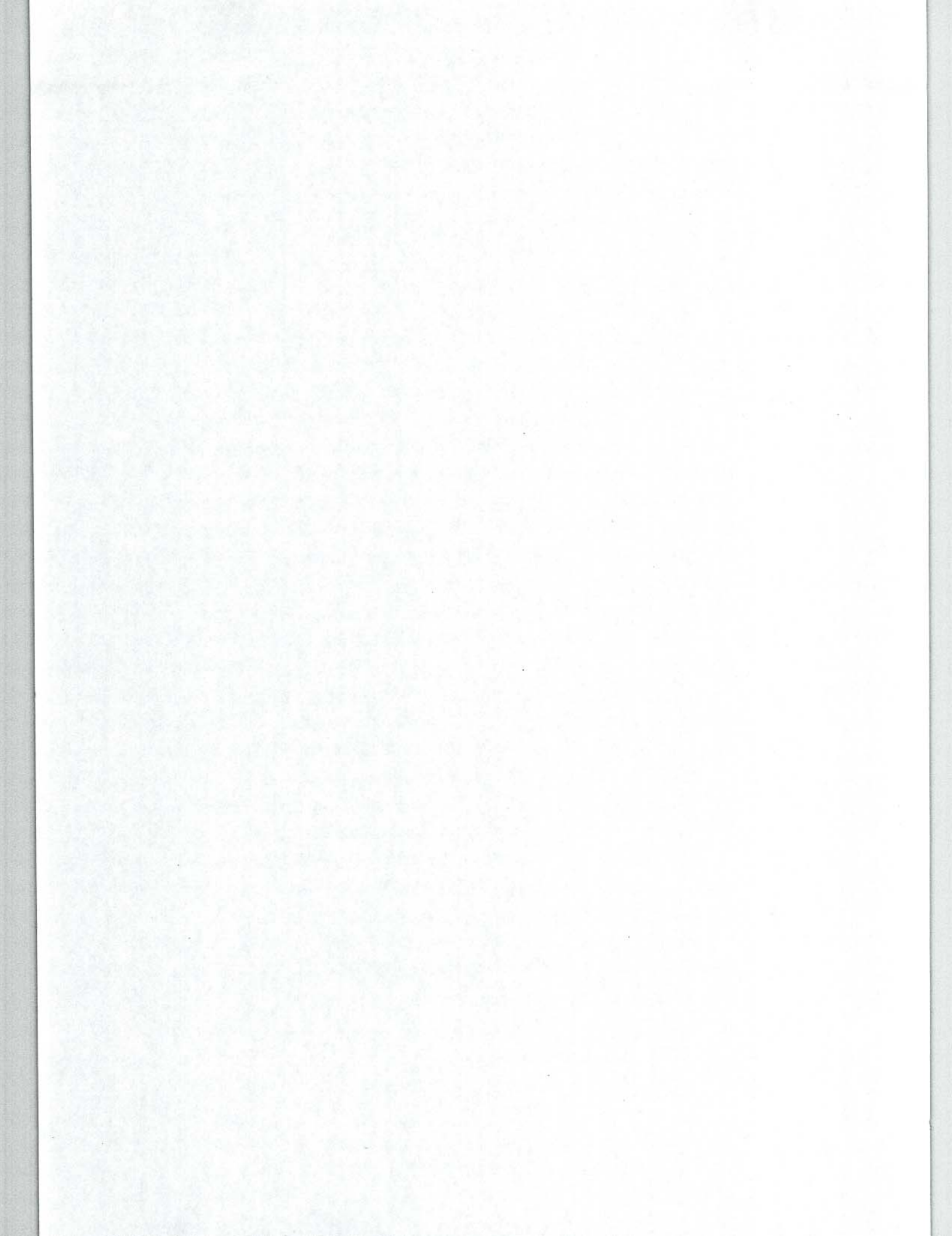

Interrogatives ( **ngafhi ? nnyi ? mini?** ) in 12 (a – c) denote the short form of the present tense with the assistance of the AGRO<sub>s</sub> ( **vha , hu and ni** ) followed by the interrogative verbs ( **dzula , lila , nwala** ).

The morphological structure of the interrogative verbs appear as follows:

(13).

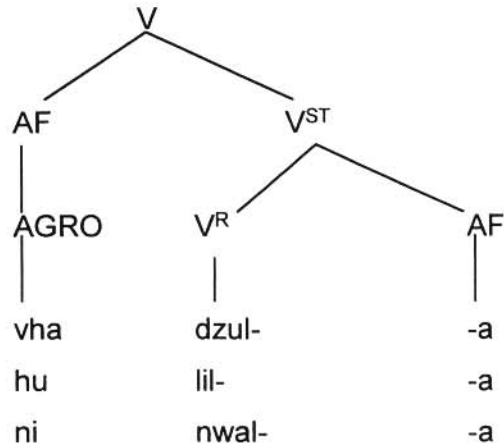

[ AGRO – V – a ]

## 7. Subject Inversion

(14) (a) Hu dzula vhahulwane.

( There lives grandparents ).

(b) Hu tshina vhana.

( There dances the children ).

Sentences 14 (a - b ) reflect a process that is known as subject inversion. The sentences as such are characterized by the appearance of the existential morpheme **hu** , verb stem ( **dzula, tshina**) and the NP<sub>s</sub> in object position. The representation in a tree diagram will be as follows:

(15)

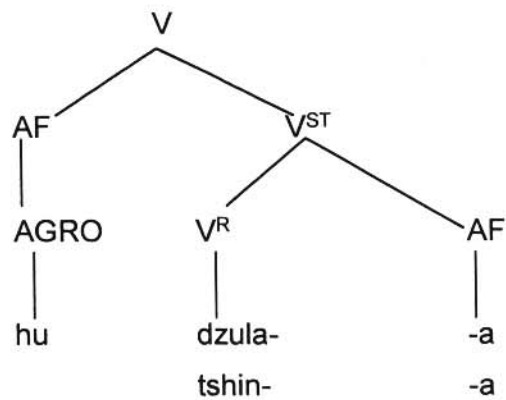

[ AGRO – V - a ]

## 8. Negatives

(16) (a) A sa tambi ( bola).

( He does not play ( the ball ).

(b) Vha tshimbila **vha sa lili**.

( They walk while they are not crying ).

Sentences 16( a - b ) indicate the short form of the present tense in the negative. The sentences are distinguished by the obligatory appearance of AGRS ( **a , vha** ) , the negative morpheme **sa** and verb stems which end in **-i** . The tree diagram representation of the morphological structure of the negatives in the short form is as follows:

(17)

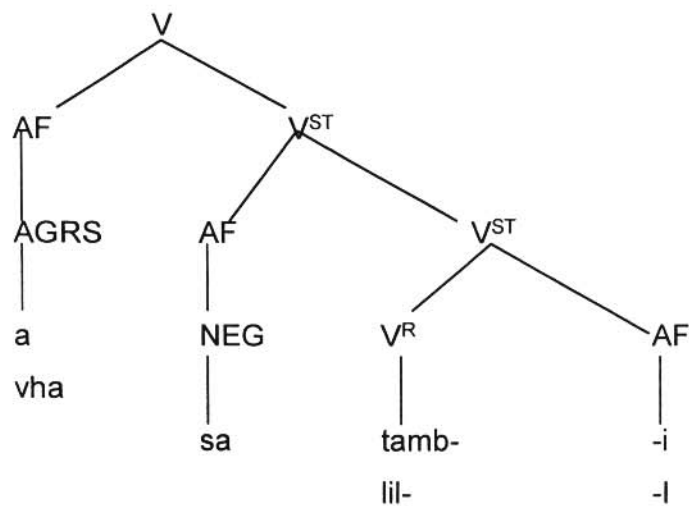

[ AGRS – sa – V – i ]

### 3.2. THE LONG FORM

#### 1. Intransitive verbs

(18) (a) Vha a lila.  
( They are crying ).

(b) Nwana u a n̄wala buguni.  
( The child is writing in the book ).

In sentences 18 ( a - b ) the long form of the present tense is characterized by the subject agreement morphemes ( **vha, u** ) followed by the affix morpheme **a** and the verb roots ( **lil -**, **n̄wal-** ) ending with the vowel **-a** . The morphological structure of the intransitive verbs in the long form would look like this.

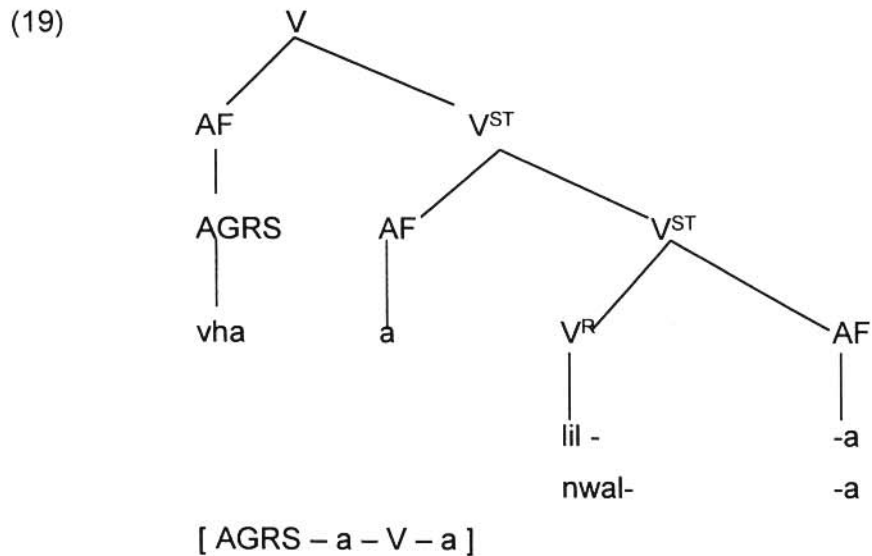

#### 2. Transitive Verbs

(20) (a) Mutukana u a rema muri.  
( The boy is chopping the tree ).

(b) Vhasidzana vha a fula mitshelo.  
(The girls are picking up the fruits ).



The long form of the present tense in 20 (a - b ) is made up of the subject agreement morphemes ( **u** , **vha** ) , the affix morpheme **a** , the transitive verb roots ( **rem -** , **ful -** ) and the terminating vowel **-a** . This can be indicated by the following morphological structure below:

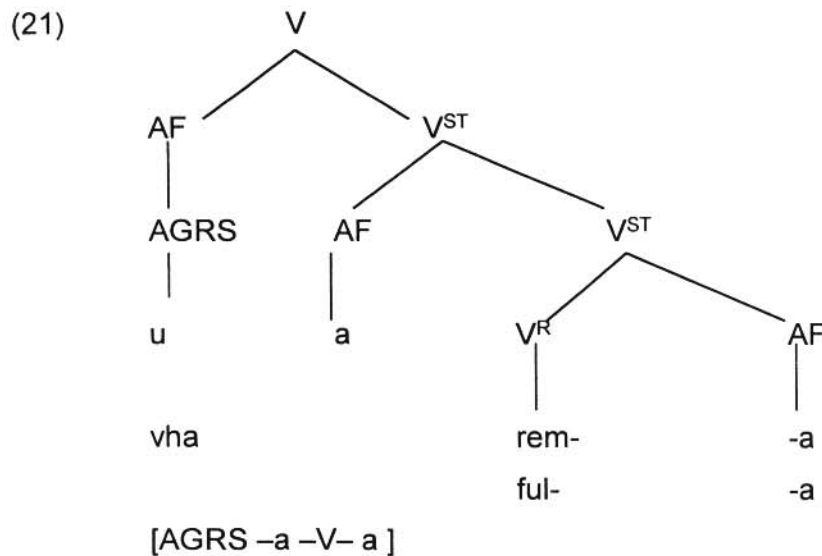

### 3. Transitive verbs with [ AGRO ]

(22) (a) Mutukana u a u rema ( muri ).

\* ( The boy is chopping it the tree ).

(b) Vhasidzana vha a i fula ( mitshelo).

\* ( The girls are picking up it fruits ).

The long form of the present tense in 22 (a - b ) is made up of the subject agreement morphemes ( **u** , **vha** ) , the affix morpheme **a** , the object agreement morpheme ( **u** , **i** ) , the transitive verb roots ( **rem-** , **ful -** ) and the verb ending **-a** . The morphological structure of the transitive verbs with AGRO may have the following representation:

(23)

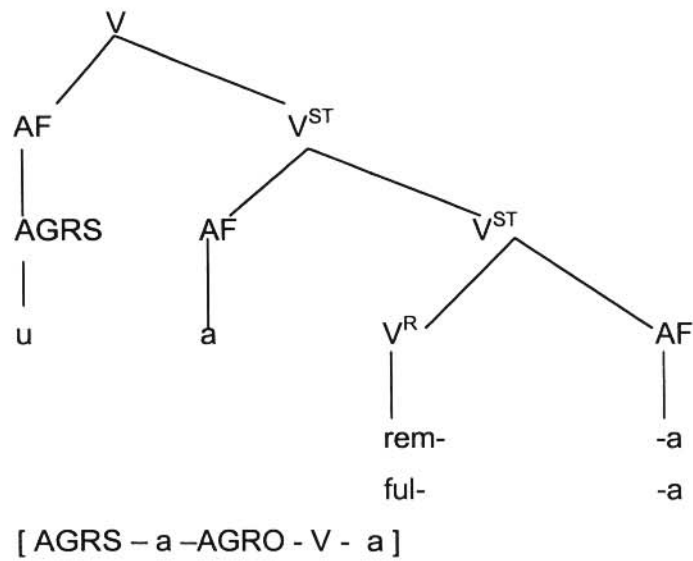

#### 4. Ditransitive Verbs

(24) (a) Mukegulu u a <sup>^</sup>nea n̄wana tshelede.  
 ( Granny is giving the child money ).

(b) Vha a rengela mutukana vhurukhu.  
 ( He / She is buying the trousers for the boy ).

The subject agreement morphemes ( **u** , **vha**), the affix morpheme **a** , the ditransitive verb roots (**ne -** , **rengel-**) ending with the terminating vowel **-a** , assist in the formation of the long form of the present tense in sentences

24( a -b). The above ditransitive verbs are represented in a tree diagram as follows:

(25)

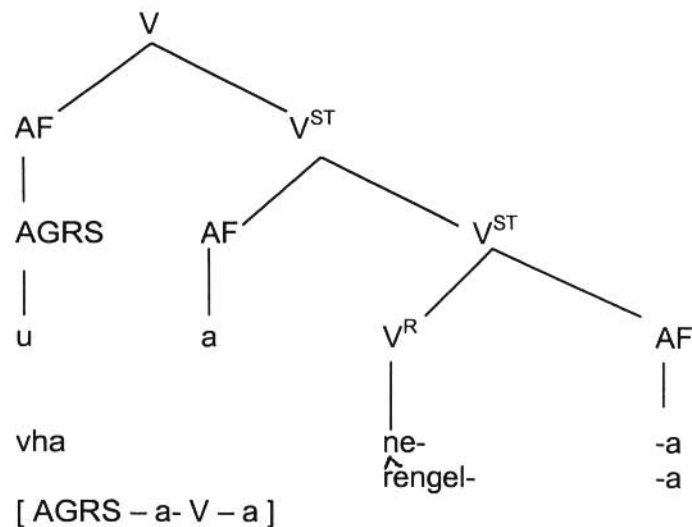

## 5. Ditransitive verbs with [ AGRO ]

(26) (a) Mukegulu u a **mu** <sup>^</sup>nea (n<sup>o</sup>wana) tshelede.

\* ( Granny is giving him / her the child money).

(b) Vha a i **fhatel** <sup>^</sup>khuhu tshitaha.

\* ( They are building the nests for it the hen).

The subject agreement morpheme ( **u** , **vha** ) together with the affix morpheme **a**, the object agreement morphemes ( **mu**, **i**) with the distractive verb roots ( **ne-** , **fhatel-** ) ending with the terminating vowel **-a**, serve in the formation of the long form of the present tense in 26( a - b ) above . The morphological structure of the ditransitive verbs with AGRO will be represented as follows.

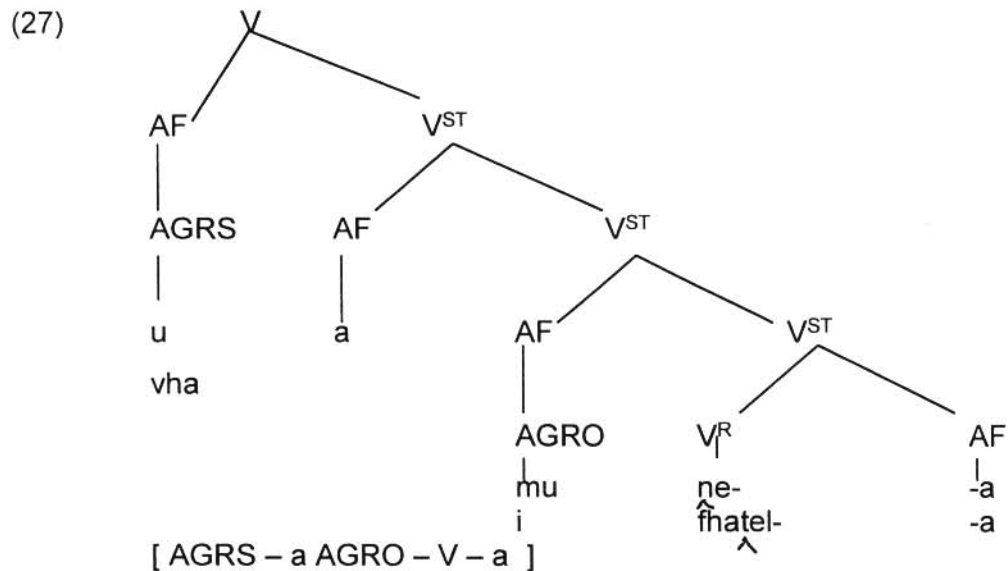

## 6. Situative Verbs

(28) (a) U bika **a tshi imba**.

( She cooks while singing ).

(b) Mpho u tshina **a tshi sea**.

( Mpho dances while laughing ).

The subject agreement **a**, accompanied by the participial morpheme **tshi**, followed by the verb roots (**imb-**, **se-**) and the terminative verb **-a**, are employed to form the situatives in the long form of the present tense in 28 ( a - b ). The following tree diagram represents the morphological structure of the situative verbs:

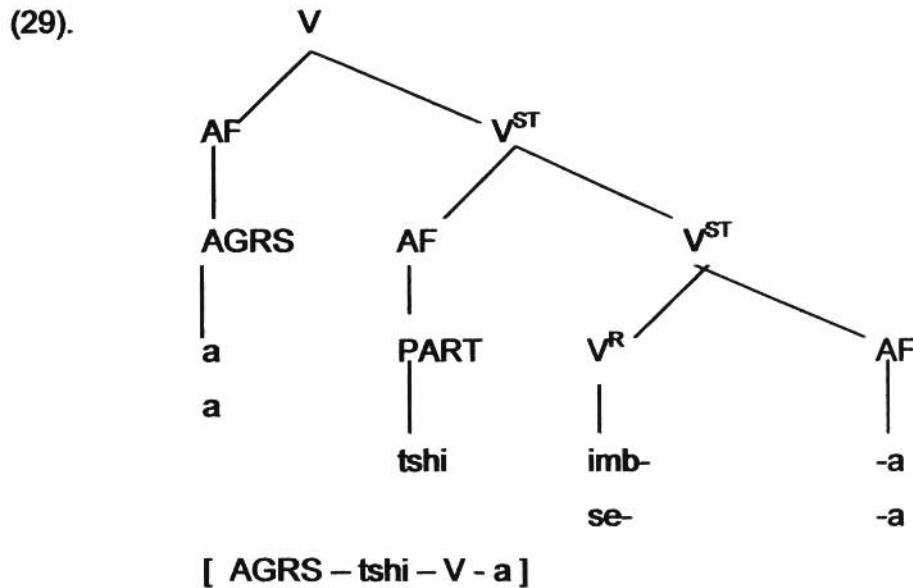

## 7. Interrogatives and interrogative modifiers

(30) (a) Vha a dzula afho?

( Should they sit there ? )

(b) Hu a lila n̄wana ufho?

( Which child is crying ? )

The above interrogatives ( **afho?** **ufho?** ) in 30 ( a - b ) and the long form morpheme **a** are employed to form the long form of the present tense. The morphological structure of the interrogative verbs ( **dzula**, **lila** ) will be shown as follows:

(31)

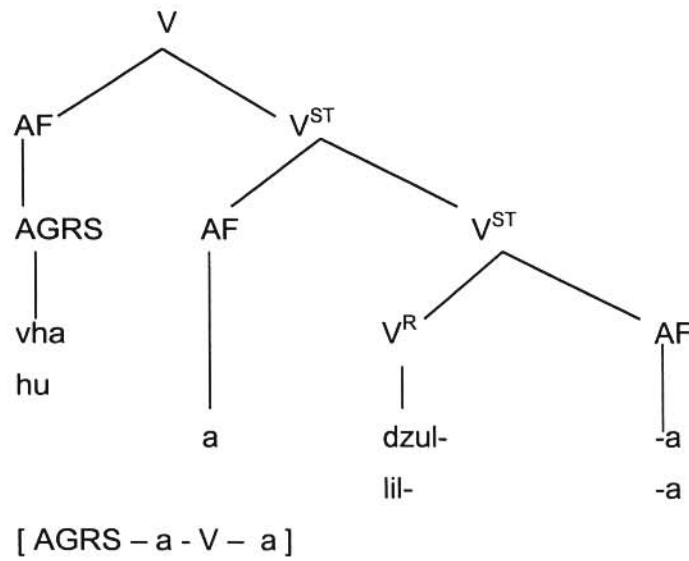

### 8. Subject Inversion

(32) (a) Hu a edela vhana.  
 ( There sleep the children ).

(b) Hu a kuvha vhasadzi.  
 ( There wash the women ).

The subject inversion in 32 ( a - b ) is characterized by the existential morpheme **hu**, the affix morpheme **a**, the verb roots ( **edel -** , **kuvh-** ) that end with the terminative vowel **-a** in the long form of the present tense. This structure can be represented in a tree diagram as follows:

(33)

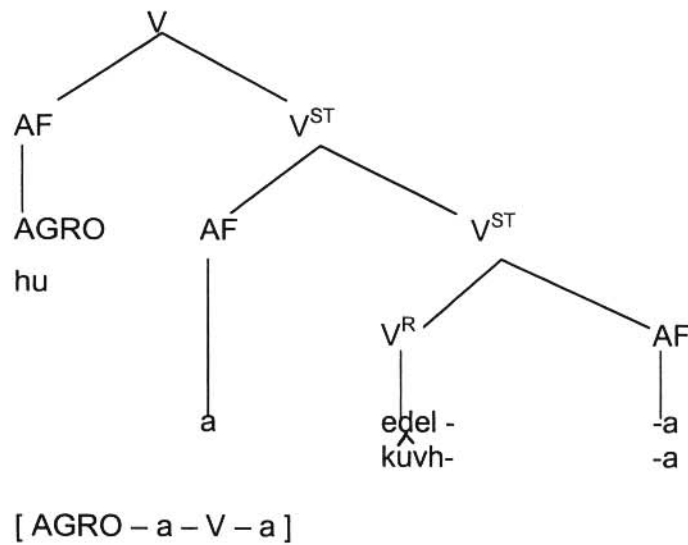

## 9. Negatives

The negative morphemes ( **a**, **sa**, **ha** ) indicated in the inflectional categories in 1.9.3. (9) denote the negative present tense as follows.

- (34) (a) Mutukana a sa remi muri.  
 ( The boy does not chop the tree ).
- (b) Vha bika vha sa imbi.  
 ( She cooks while not singing ).

The sentences in 34 ( a - b ) are distinguished by the usage of the negative morpheme **sa**, the verb roots which normally end in **-a** and in the affix **-i**. All these features assist in the construction of the long form of the present tense in the negative. The morphological structure of the negatives in the long form of the present tense will be as follows:

(35)

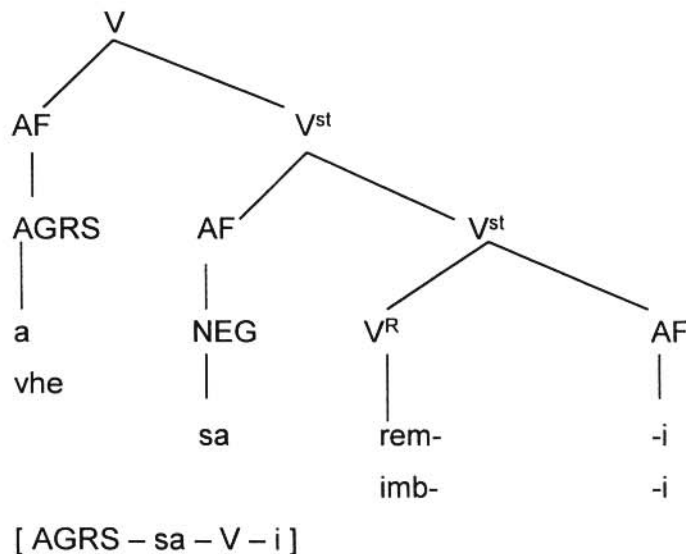

## 4. THE SEMANTIC SIGNIFICANCE OF THE PRESENT TENSE

The Present Tense expresses a variety of meanings in Tshivenda. The meanings that this study will focus on are as follows:

#### 4.1. TEMPORAL SPECIFICATION ( DEIXIS )

Temporal specification is when the time is specified by the speaker. Temporal specification may be determined by the place and time or by the use of adverbs in the present tense. Frawley ( 1992 : 340 ) argues:

Temporal deixis are treated at greater length under tense and time. The principal reference point for temporal deixis is the present, the contextual time at which the utterance occurs and indicates the coincidence of time of the event.

##### 1. Place and Time

Du Plessis and Madadzhe ( 1999 : 143 ) maintain:

The present tense indicates the period of time which is happening now, not the past or the future, but now.

The following sentences help to indicate the place and time of the occurrence of actions:

(36) (a) Nwana u a kambiwa.  
( The child drinks ).

(b) Mvula i a na.  
( It rains ).

(c) Hu a fhisa Nzhelele.  
( It is hot at Nzhelele ).

The hearer may notice that the actions are taking place now, in sentences 36 (a – c). Temporal specification can be shown if the speaker and the hearer are not far from the actions. The participants can physically see the child who drinks in 36 (a) or can notice the manner in which it rains in 36 (b) , or how hot it is in Nzhelele

as indicated in sentence 36 ( c ) . But if the hearer is not close enough the present tense may denote the drinking habit of the child or the way in which it usually rains in that specific place or how hot it is in Nzhelele.

## 2. The use of adverbs

Sentences may be constructed in such a way that adverbs end up denoting the present tense. The adverb which denotes the time is known as the adverb of time.

(37) ( a ) Ndi a <sup>^</sup>da zwino.  
( Now I come).

(b) Tsimbi i a lila zwenezwino.  
( The bell is ringing very soon ).

The adverbs ( **zwino** , **zwenezwino**) in sentences 37 (a - b ) denote that the actions are taking place in the present moment . These adverbs indicate the relationship between place and time and how far or near the participants are from the actions. The period between the adverb **zwino** and the speaker, and the adverb **zwenezwino** and the speaker indicate the temporal specification. It might be now or very soon but it can take some few minutes before the actions are carried. Poulos ( 1990 : 412 ) points out:

One can here note some relationship between the “ place” and “ time” notions the adverb **zwino** expresses proximity in time **now** , while the demonstrative expresses proximity in distance or space. Compound demonstratives based on **zwino** are also used as adverbs, e.g. **zwenezwino** meaning “ at this very moments:

The confirmation about the meaning of this adverb is given by Du Plessis and Madadzhe ( 1999 : 145) when they state:

The word **zwino** when appearing with sentences in the present tense, indicates that the action is



happening there and then.

## 4.2. HABITUAL ACTION

Du Plessis and Madadzhe ( 1999:145 ) clearly define the habit as:  
^

The settled practice or tendency. The practice is repeated on a regular basis that ultimately is only associated with a particular person or agent.

The Tshivenda present tense can also signify an action that is usually performed . The following actions in the sentences below are customarily done by the subject of the sentence or the external argument:

(38) ( a ) Ndi bika tshitangani.  
^  
( I cook in the kitchen).

(b) Mufumakadzi u tshina malende.  
(The lady dances the “ malende” dance ).

Actions in sentences 38( a - b ) express the habits of the subjects . Traditionally, Vhavenda people are used to cook in the kitchen, therefore sentence 39 (a) may signify that the speaker is used to cook in the kitchen or it is his / her custom to cook in the kitchen. “ Malende” in sentence 38( b) is a traditional dance which the lady enjoys dancing or the sentence signifies that it is her tendency to dance the traditional dance “ malende. “

## 4.3. EMPHASIS

Du Plessis and Madadzhe ( 1999: 145 ) regard an emphasis as follows:  
^

Emphasis is when one attaches importance to the issue under discussion . The long form of the present tense expresses emphasis when appearing in instances such as the following:

(39) (a) U a u rema muri.  
( He is chopping it the tree).

(b) Vha a mu rengela zwiambaro.  
( He is buying for him the clothes ).

The AGROs ( **u** , **mu** ) lay emphasis on the verbs ( **rema**, **rengela** ) in sentences 39 ( a - b ) . The sentences put more emphasis on the fact that no one else is able to chop or buy what is being referred to by the subject predicate clause.

#### **4.4. ONGOING ACTION**

Ongoing actions are actions that continue to happen as the speaker conveys his / her feelings, thoughts or ideas:

(40) ( a ) Musidzana u thetshelesa mubvumo.  
( The girl listens to a sound).

(b) Mutukana u vhona nndwa.  
( The boy watches a fight).

The actions in sentences 40 ( a - b ) are taking place as the speaker conveys his / her message. The meaning of the on-going – action must not be confused with that of the present continuous tense, as in sentences below:

#### **The Present Continuous Tense**

(41) (a) Ni khou itani?.  
( What are you doing?.

(b) Musidzana u khou bika.  
( The girl is cooking ).

The above sentences 40( a - b ) – 41 ( a - b ) are in the present tense, except that sentences 41 ( a - b ) express another type of the present tense known as the present continuous tense.

## 5. CONCLUSION

In this chapter, the definition, morphological structure and semantic significance of the present tense were discussed. The definition of the present tense depends mostly on the semantic expressions.

The morphological structure of the present tense is clear and concise. The long present tense contains a distinctive affix morpheme **a** as in sentences 2.3.2. The short present tense lacks the affix morpheme **a** as shown in 2.3.1. In general the agreement morpheme determines the present tense in the sentence. The subject agreement morpheme has influence on the subject noun and the object agreement morpheme agrees with the object noun.

The meanings of the present tense may be shown in a diagram as follows:

<b>Present Tense Morphemes</b>	<b>Temporal Specification</b>	<b>Habit</b>	<b>Emphasis</b>	<b>Ongoing Action</b>
AGRS	+	+	-	+
AGRO	-	-	+	+
NOUNS	+	-	-	-

## CHAPTER 3

### THE PAST TENSE

#### 1. INTRODUCTION

The aim of this chapter is to examine the morphological , syntactic and semantic features of the past tense in Tshivenda. The aim will be achieved by concentrating on aspects such as the definition of the past tense, types of verbs that occur in the past tense, agreement morphemes, structures and various meanings that are associated with the past tense.

#### 2. DEFINITION OF THE PAST TENSE

There are several definitions of the past tense but all of them indicate that the past tense shows an action or event that has been completed, or that has already occurred . The definitions that follow support this view.

Mc Magh ( 1970:59 ) defines the past tense as follows:

The tense refers to action wholly in the past, when we look at it from the present moment . It may have happened only seconds ago because the time when the action happened is always stated or implied in the context.

The definition given by Poulos ( 1990 :259-260) states:

The perfect tense generally expresses an action that took place at some time in the past. The prefix –o- is the characteristic marker of this tense. ( in Tshivenda ).

Ziervogel et al. (1972 :45 ) concur with the above authors:

The perfect is a tense form expressing a completed action. The perfect form of the predicate consists of the subject concord to which the perfect formative –o is added followed by the verb stem.

- (1) (a) (i) **Ri** <sup>◌</sup>nwala bugu.  
( We write the book ).
- (ii) **Ro** <sup>◌</sup>nwala bugu.  
( We wrote the book ).
- (b) (i) Vhana **vha** phasa vhothe.  
( The children pass them all ).  
( All the children pass)
- (ii) Vhana **vho** phasa vhothe.  
( The children passed them all ).  
( All the children passed)
- (c) (i) **Nwana** <sup>◌</sup>u xedza phenisela.  
( The child loses a pencil ).
- (ii) **Nwana** <sup>◌</sup>o xedza phenisela.  
( The child lost a pencil ).

The perfect morpheme -o denotes the perfect tense and the subject agreement ( **ri** , **vha** and **u** ) change into ( **ro** , **vho** and **o** ) in sentences 1 ( a – c )

### 3. THE MORPHOLOGICAL STRUCTURE OF THE PAST TENSE

The morphological structure of the past tense is explained by Du Plessis and Madadzhe ( 1999 :147 ) when they state:

In Venda the perfect tense is conspicuous by the usage of the morpheme **-o**. This morpheme is attached to Agra

The perfect morpheme **-o** as indicated by the definitions above changes the subject agreements in the present tense to form the subject and object agreements in the past tense as shown by the table in example (8) in chapter 1. The past tense agreement morphemes can be used with or without the corresponding nouns, for example:

- (2) (a) Musadzi **o** bika vhuswa.  
( The woman cooked the porridge ).
- (b) **O** bika vhuswa.  
(She cooked porridge ).
- (c ) Musadzi **o vhu** bika vhuswa.  
( The woman cooked it the porridge ).
- (d ) Musadzi **o vhu** bika.  
( The woman cooked the porridge ).
- ( e ) Tsimbi **yo** lila.  
( The bell rang ).
- (f ) **Yo** lila tsimbi.  
( It rang the bell ).
- ( g ) **Yo** lila.  
( It rang ).

The past tense agreement morpheme **-o** is used with or without the nouns in sentences 2 (a – d )

The way in which these changes come about can be illustrated in a form of a table as follows:

(3)

NOUN CLASS	NOUN PREFIX	PAST TENSE MORPHEME O CHANGES PRESENT TENSE SUBJECT AGREEMENTS INTO PAST TENSE SUBJECT AGREEMENTS
1 <sup>st</sup> Singular		ndi + -o > ndo
1 <sup>st</sup> Plurals		ri + -o > ro
2 <sup>nd</sup> Singular		u + -o > o
2 <sup>nd</sup> Plurals		ni + -o > no
1	Mu-	u + -o > o
2	Vha-	vha + -o > vho
3	Mu-	u + -o > wo
4	mi-	i + -o > yo
5	Li- ^	li + -o > lo ^        ^
6	Ma-	a + -o > o
7	Tshi-	tshi + -o > tsho
8	Zwi-	zwi + -o > zwo
9	N-	i + -o > yo
10	Dzi-	dzi + -o > dzo
11	Lu-	lu + -o > lwo
14	Vhu -	vhu + -o > vho
15	U-	hu + -o > ho
16	Fha-	hu + -o > ho
17	Ku-	hu + -o > ho
18	Mu-	hu + -o > ho
20	Ku-	ku + -o > kwo
21	Di- ^	li + -o > lo ^        ^

As already stated various categories that appear with the past tense morpheme will be discussed.

### 3.1. INTRANSITIVE VERBS

(4) (a) (i) Milambo i a dala.  
 ( The rivers are full ).

(ii) Milambo yo dala.  
 ( The rivers were full ).

(b) (i) Nwana u a wa.  
 ( The child is falling ).

(ii) Nwana o wa.  
 ( The child fell ).

The intransitive verbs ( **dala, wa** ) denote the past tense due to the usage of the past tense morpheme **o** . The perfect morpheme **o** changes the subject agreement **i** of the present tense into the subject agreement morpheme **yo** of the past tense in sentence 4 ( a ) . In sentence 4 ( b ) the perfect morpheme **o** changes the subject agreement **u** of the present tense into the subject agreement **o** of the past tense. The morphological structure of the intransitive verbs in the past tense can be represented as follows:

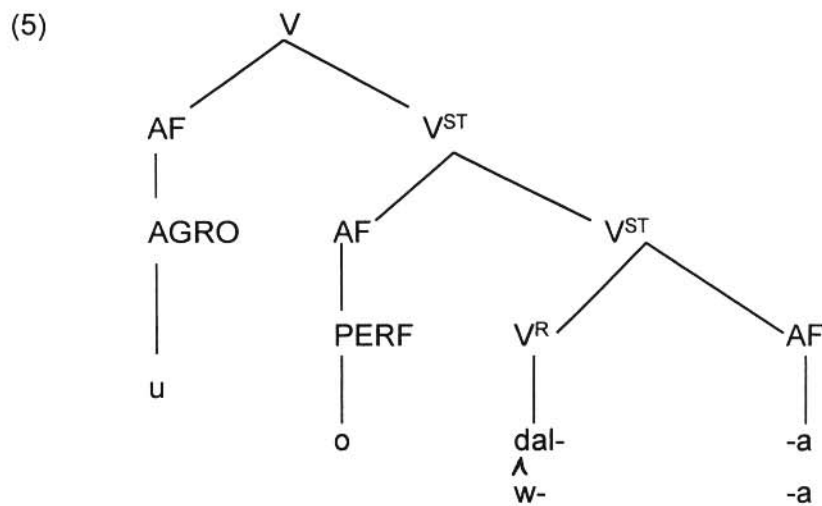

[ AGRS – O – V – a ]



### 3.2. TRANSITIVE VERBS

(6) (a) (i) Tendani u <sup>o</sup>nwala mulingo.  
 ( Tendani writes the examination ).

(ii) Tendani o <sup>o</sup>nwala mulingo.  
 ( Tendani wrote the examination).

(b) (i) Ndi lifha mulandu.  
 ( I am paying the fine ).

(ii) **Ndo** lifha mulandu.  
 ( I paid the fine ).

The transitive verbs ( <sup>o</sup>nwala , lifha ) help in the construction of the past tense in sentences 6 (a- b) . The perfect morpheme **o** changes the subject agreement **u** into **o** in 4 (a), and the subject agreement **ndi** into **ndo** in 6 (b) . The tree diagram represents these as shown below:

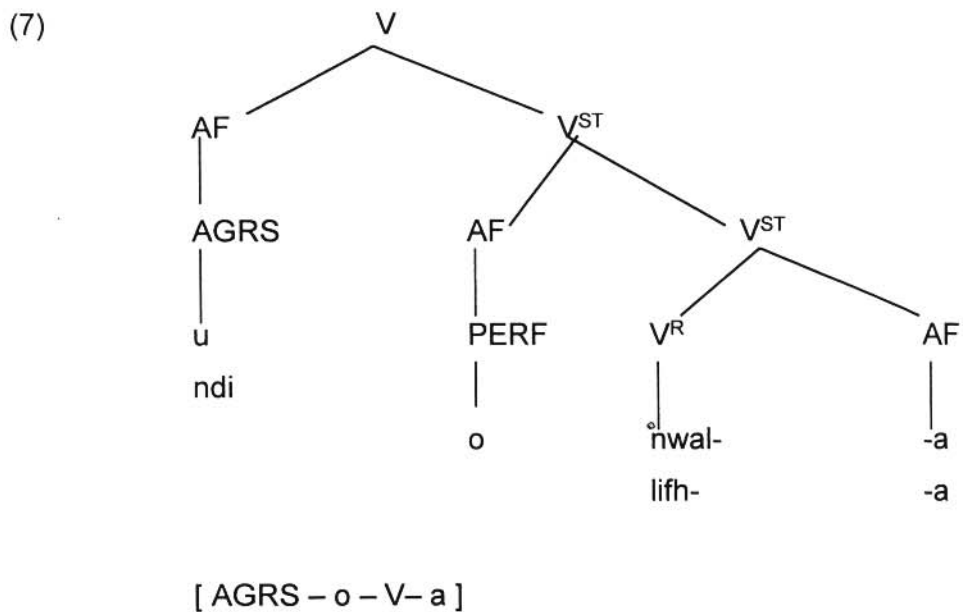

### 3.3. TRANSITIVE VERBS WITH [ AGRO ]

(8) (a) (i) Mutukana u a i raha bola.  
 ( The boy is kicking it the ball ).

(ii) Mutukana o i raha bola.  
 ( The boy kicked it the ball ).

(b) (i) Vha a **vhu** tshea vhurotho.  
 ( He / she is slicing the bread ).

(ii) **Vho vhu** tshea vhurotho.  
 ( He / she sliced it the bread ).

Sentences 8 ( a – b ) have been formed by the transitive verbs ( **raha** , **tshea** ) with the object agreements ( **i** , **vhu** ). The perfect morpheme **o** changes the subject agreement **u** in sentence 8 ( a ) into **o** and the subject agreement **vha** into **vho**. The morphological structure of the transitive verbs with [ AGRO ] will be represented thus:

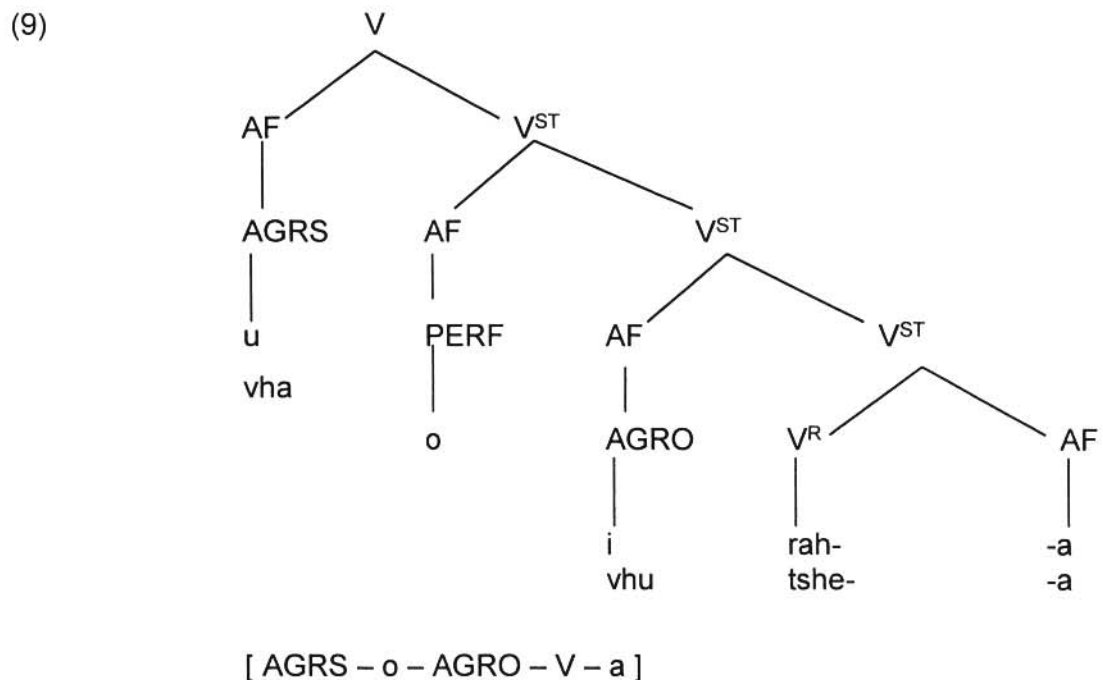

### 3.4. DITRANSITIVE VERBS

(10) (a) Mme – muhulu **vho** fha **ńwana** tshelede.  
 ( An aunt gave the child money ).

(b) Mudededzi **o** **ńwalela** mugudiswa vhurifhi.  
 ( The teacher wrote a letter to the learner ).

The sentences are constructed by the AGRS<sub>s</sub> ( **vho**, **o** ), the ditransitive verbs ( **fha**, **ńwalela** ) to denote the past tense in 10 ( a – b ). The following tree- diagram represents these :

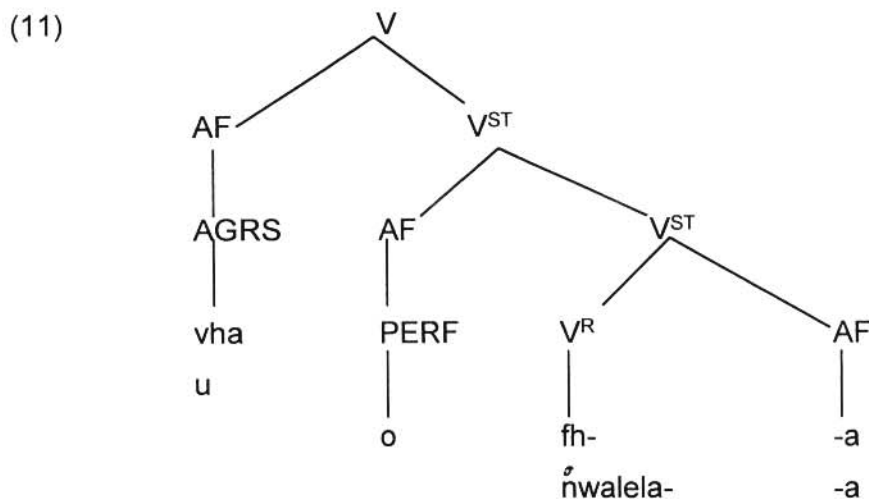

[ AGRS – o – V – a ]

### 3.5. DITRANSITIVE VERBS WITH [ AGRO ]

(12) (a) Mme- muhulu vho **mu** fha ( **ńwana** ) tshelede.  
 ( An aunt gave him / her the child money ).

(b) Mudededzi o **mu** **ńwalela** mugudiswa vhurifhi.  
 ( The teacher wrote a letter to him / her ).

The sentences are characterized by the subject agreements ( **vho**, **o** ), the object agreements **mu** and the ditransitive verbs ( **fha**, **ńwalela** ) to denote the past tense in sentences 12( a – b ). The morphological structure will be as follows:

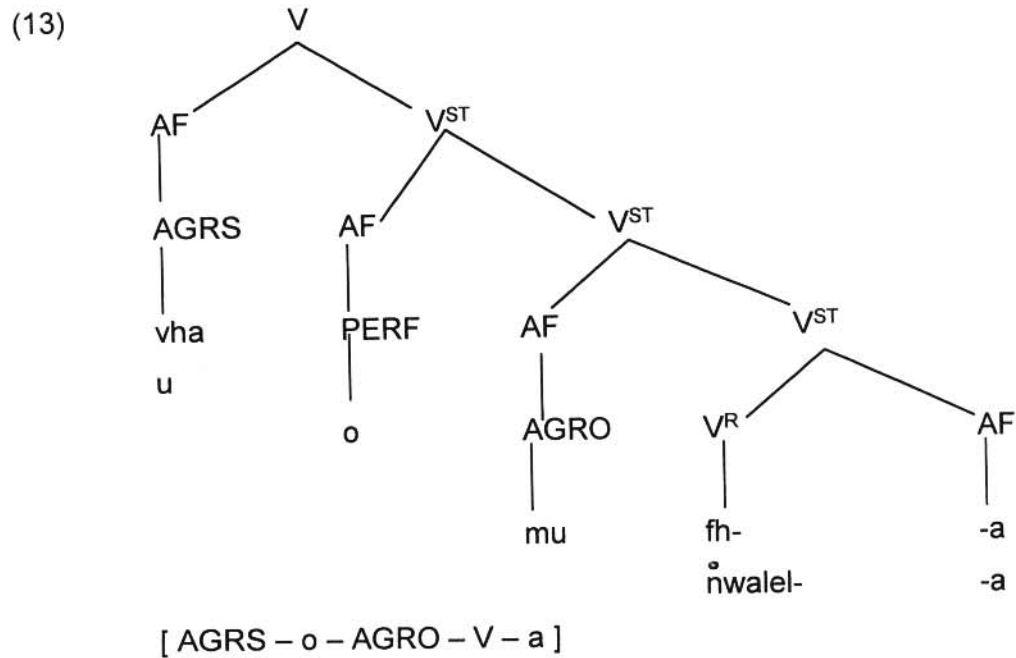

### 3.6. TEMPORAL SPECIFIERS

#### 1. Locatives

(14) (a) Ro edela **Makhado**.  
 ( We slept at Makhado ).

(b) Vho kuvha zwiambaro **mulamboni**.  
 ( They washed the clothes in the river ).

The above sentences are in the past tense. The actions occurred in specific areas as indicated by the locatives ( **Makhado** , **mulamboni** ).

#### 2. Adverbs

The majority of adverbial clauses are temporal specifiers

(15) (a) O **da** **luvhili**.  
 ( He came twice ).

(b) **Nwana** o tshimbila **lunzhi**.  
 ( The child ate several times ).

The past tense can work together with the adverbs ( **luvhili**, **lunzhi**) as in sentences 15 (a –b ).

### 3.7. INFINITIVE

(16) (a) Ndo ya [ u runga ].  
( I went to sew ).

(b) Ro swika [ u bika ].  
( We arrived to cook ).

The infinitive clauses [ **u runga** , **u bika** ] depend on the past tense clauses [ **ndo ya**, **ro swika** ] to signify the past tense in sentences 16 (a – b).

### 3.8. URI – CLAUSE

(17) (a) Vho takalela [ uri vho phasa ( mulingo )].  
( She is happy that he passed the examination ).

(b) Ndo zwi vhona [ uri o fhedza ( mushumo) ].  
( I realized that he / she completed the work ).

The **uri – clause** is characterized by the complementizer **uri** , the subject agreements ( **vho**, **o** ) and the verbs ( **phasa**, **fhedza** ) to indicate the past tense in sentences 17 (a- b )

### 3.9. INTERROGATIVE

(18) (a) Vho edela **ngafhi**?  
( Where did she slept ?).

(b) Tsho fa nga **mini**?  
( What causes its death ? ).

- (c) No i xedza **lini** ?.  
( When did you lost it ?).

The interrogative words **ngafhi**, **mini** and **lini?** used in the sentences 18( a–c) denote the past tense by virtue of appearing with the morphemes **vho**, **tsho** and **no**.

### 3.10. PARTICIPIAL CLAUSE

- (19) (a) Ro swika [ a tshi bika ].  
( We arrived while she is cooking ).

- (b) Mmbwa yo gidima [ i tshi huvha ].  
( The dog ran while barking ).

The participial clauses [ **a tshi bika** ] and [ **i tshi huvha** ] in sentences 19 ( a – b ) are not in the past tense but appear in the present tense. Although the participial clauses are in the present tense, their message is however in the past tense. This is so because of the main clauses which are in the past tense ( **ro swika**, **mmbwa yo gidima** ).

### 3.11. NEGATIVE

The negative in the past tense is formed by the negative ( **a** , **ngo** ) as indicated in the inflectional categories in 1.9.3. (9). In this regard Ziervogel et al. (1972 :48) indicate:

The negative of the perfect tense is formed by putting negative **a** before the perfect concord, inserting **ngo** before the verb. The negative of class Mu- ( class 1 ) and class Ma- ( class 6 ) in the perfect tense is formed by means of the contraction of the negative **a** ( < **ha** ) and the concord **o** to **ho** .

The discussion above can be supported by the following examples:

(20) (a) Liivha a lo ngo fhufha.  
 ( The dove did not fly ).

(b) Vhasadzi a vho ngo renga swigiri.  
 ( The woman did not buy the sugar ).

(c) Munna ho ngo tuwa.  
 ( The man did not leave ).

(d) Maivha ho ngo fhufha.  
 ( The doves did not fly ).

The negative morphemes ( a, ngo ) and the subject agreement morphemes ( lo, vho ) are inserted to denote the past tense in sentences 20 ( a – b ) . In sentences 20 ( c - d ) the negative ngo and the subject agreement morpheme ho are inserted to denote the past tense. The morphological structure of the negatives in the past tense can be shown as follows:

(21) (a) The negative verb structure of 20 ( a – b ) in the past tense:

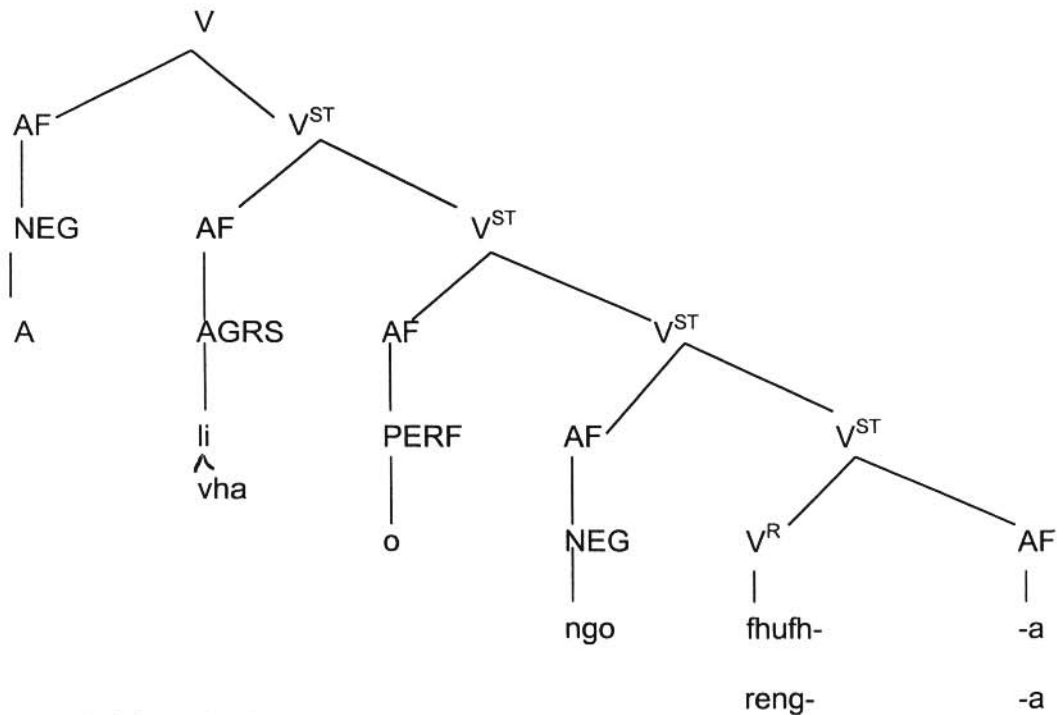

(b) The negative verb structures of 20 (c-d ) of noun class 1 (Mu -) and class 6 (Ma -)

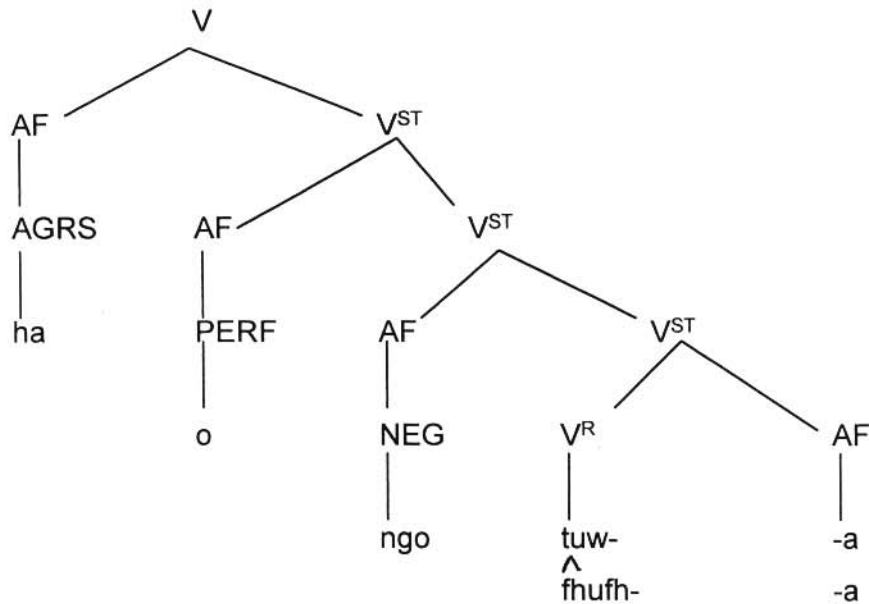

[ AGRS ( ha ) -o- ngo - V - a]

### 3.12 COPULATIVE

22 (a) Mulalo **o vha e mudededzi** Tshakhuma.  
( Mulalo was a teacher at Tshakhuma ).

(b) Tendani **o vha e mudzulatshidulo** mulovha.  
( Yesterday Tendani was a chairperson ).

Copulative clauses in sentences 22( a-b) are made up of the subject agreement **o**, the copulative formative **vha**, relative morpheme **e** and the copulative nouns ( **mudededzi**, **mudzulatshidulo**) to form the copulatives in the past tense.

## 4. THE SEMANTIC SIGNIFICANCE OF THE PAST TENSE

There are several meanings which the past tense signifies . The most important are:



#### 4.1. Past Tense

Du Plessis and Madadzhe (1999 :149) refer to the meaning of the past tense as follows:

It indicates an action that has already occurred  
temporal nouns may also be used to remove  
doubt as to when indeed an action took place:

The following examples can be considered in conveying the meaning of the past tense.

(23) (a) No la **matsheloni**.

( You ate in the morning ).

(b) Vhathu vho da **mulovha**.

( People came yesterday ).

( c) Ro tamba bola **mbamulovha**.

( We played the ball a day before yesterday ).

(d) **Mahola** vho phasa vhothe.

( Last year they passed all of them ).

(e) Mbudzi dzo xela **madekwe**.

( The goats lost last night ).

(f) **Mbamahola** ho lovha makhulu wawe.

( A year before last his granny died ).

( g ) Ndo fhata **kale**.

( I built long ago ).

The temporal nouns ( **matsheloni**, **mulovha** , **mbamulovha**, **mahola**, **madekwe** , **mbamahola** and **kale**) confirm that the actions as given in 23( a-g ) took place in the past.

## 4.2. PRESENT TENSE

There are some instances where the past tense expresses the meaning of the present tense. The past tense expresses the ongoing actions:

(24) (a) Vhasidzana vho dzula khatsho.

( The girls sit on it ).

(b) Ndo edela.

( I am asleep ).

Morphologically, the above sentences reflect the past tense form, but what they denote is in the present. Sentences 24( a-b ) indicate that the action is still going on or continuing.

## 4.3. EMPHASIS

(25) (a) Nwana o vhu bika vhuswa.

( The child cooked it the porridge ).

(b) Vho mu rwa nwana.

( He beaten him the child ).

The [ AGRO<sub>s</sub> ] put more emphasis on the action done by the external argument. In sentences 25 (a- b ) the actions **cooking** and **beating up** were excessively done.

## 4.4. RECENT PAST

Recent past indicates an action which began in a time shortly before the present moment:

(26) (a) Tendani o ya doroboni.

( Tendani went to town ).

(b) Musadzi o ka madi.

( The woman fetched water ).

The actions ( o ya, o ka ) in sentences 25 (a- b ) occurred immediately before the present moment. One may call the recent past the pre- present time.

#### 4.5. REMOTE PAST

Remote past indicates an action which ( had ) happened far away in place or time:

- (26) (a) Rendani o vhuya a mala Mushoni.  
( Rendani once married Mushoni ).
- (b) O vhuya a vha mudededzi.  
( He / She was once a teacher ).
- (c) Ndivhuwo o vha e khonani yawe.  
( Ndivhuwo was once his / her friend ).
- (d) O vha e dokotela.  
( He / She was a doctor ).
- (e) Gondeni vho dzula kale.  
( He / She lived Gondeni long ago ).
- (f) Vho shuma hone mulovha.  
( He / She worked there yesterday ).

Remote past in sentences 26 (a- f ) signifies a point or a more specific period of time expressed by the past tense. The point or period in time is either expressed by a temporal circumstance or by the auxiliary verb **vhuya**.

#### 4.6. SEMANTIC VERB ROOTS

Semantics deals with the study of meaning. In this section the verb roots such as inchoative, stative, and actional verb roots will be discussed.

## 1. Inchoative Verb Roots

Inchoative verbs indicate some or other entrance into a state:

(27) (a) Ndo neta.

( I was tired ) or ( I am tired ).

(b) Nwana o edela.

( The child <sup>^</sup>was asleep ) or ( The child is asleep ).

(c) O fariwa.

( He / She was imprisoned ) or ( He / She is imprisoned ).

(d) Vho dinalea.

( They were worried ) or ( They are worried ).

(e) Sara o onda.

( Sara was lean ) or ( Sara is lean ).

The verb roots **net<sub>3</sub>- edel -** , **far-**, **dinal-** and **ond-** indicate a state of "being" , " becoming" or "getting" into an action as indicated in sentences 27( a – e )

## 1. Stative Verb Roots

Stative verb roots express some or other state, be it mental or physical.

(28) ( a) O vha a tshi penga.

( He was mad ).

(b) Ho vha hu tshi rothola mulovha.

( It was cold yesterday ).

( c) O vha a tshi lwala.

( He / She was ill )

(d) Ho vha hu tshi fhisa.

( It was hot ).

(e) Muri wo vha u tshi mela.

( The tree was starting to grow ).

Sentences 28 (a – e ) indicate the mental state of a person and the physical state in a geographical perspective.

### 3. Actional Verb Roots

Actional verb roots do not involve the processes or state in their meanings. The verb roots meaning refer to the action.

(29) (a) Vho rema muri.

( He / She chopped the tree ).

(b) Musidzana o bika vhuswa.

(The girl cooked the porridge).

( c ) Vha sidzana vho tshina tshigombela .

( The girls were dancing “ tshigombela “ ).

(d) Ro raha bola.

( We kicked the ball).

(e) Ndo kuvha zwiambaro.

( I washed the clothes ).

The meanings given indicate the action of the verb roots **rem-**, **bik-**, **tshin-** , **rah -** , and **kuvh -** in sentences 29 (a – e).

### 5. CONCLUSION

The definition, structure and interpretation of the past tense sentences have been discussed in this chapter. The intransitive, transitive and ditransitive verbs have also been examined.

The chapter has also dealt with the temporal specifiers, the uri- clause, the interrogative, negative and the copulative. The past tense is distinguished by its own peculiar morphological structure, namely, the appearance of the morpheme –o. The negative morphemes ( a , ngo ) can also appear in sentences in the past tense.

The chapter has shown that the past tense denotes a variety of meanings. These meanings can be illustrated as follows:

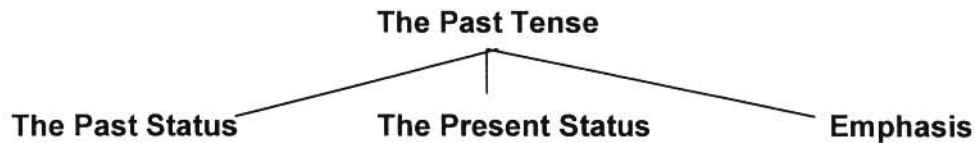

The chapter shows that the past tense locate events in place and time in the sentence. Remoteness and recent past indicate when the actions took place in the past.

The chapter also focused on several types of verbs. These are as follows:

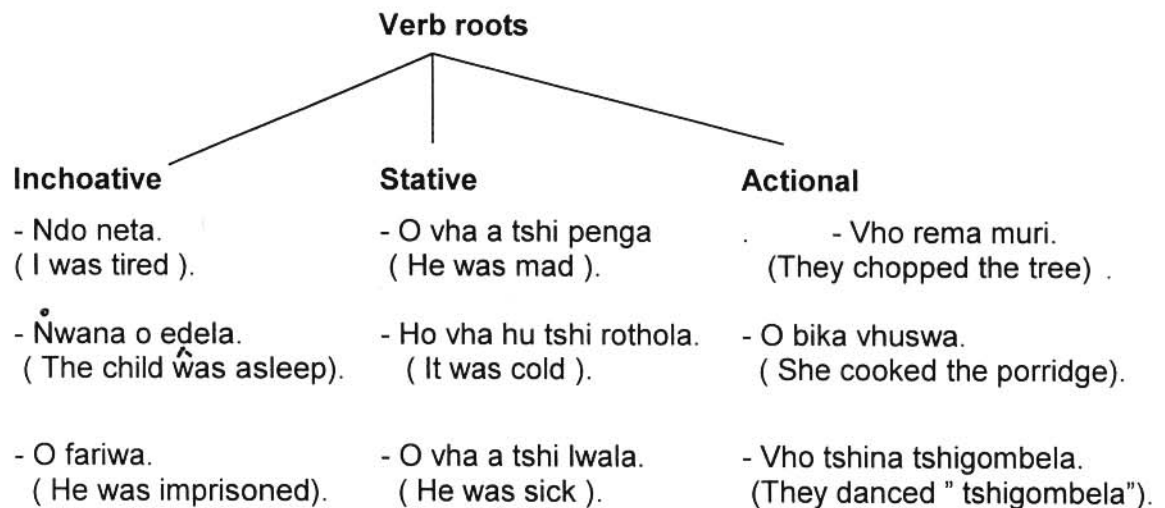

## CHAPTER 4

### THE FUTURE TENSE

#### 1. INTRODUCTION

The aim of this chapter is to examine the future tense in Tshivenda. The discussion will focus, on the formative structure and meaning of this tense.

In this chapter there will be an account of the modal verb such as the participial, potential, copulative, consecutive, and the subjunctive. The locative, relative with the relative marker [ **-ho** ], uri – clause, interrogative, transitive verb, transitive verb with [AGRO ], negative and inversion will also be dealt with.

A variety of meanings associated with the future tense will also receive scrutiny: habit, present, status, volition, willingness or intention, prediction, condition and purpose.

#### 2. DEFINITION OF THE FUTURE TENSE

The future tense expresses an action that will take place in the future. The use of the future morpheme (do) involves the expression of futurity as indicated below:

(1) (a) Vha **do** lila.  
( They will cry ).

(b) Ri **do** nwala mulingo.  
( We shall write the examination ).

The traditional idea that the future morpheme (do) denotes the future tense is still held by some scholar (Ziervogel, 1972; Du Plessis and Madadzhe 1999; Milubi; 1996). The future morpheme (do) is not the only marker of the future tense in

Tshivenda. The potential morpheme **nga** and the copulative morpheme **vha** may also indicate the future tense in different contexts:

(2) (a) Ndi **nga** vhuya matshelo.

( I may be back tomorrow ).

(b) [ A **vha** mudededzi ] u a renga .

( If he will be a teacher, he will buy ).

(c) Vha guda **vha** a phasa.

( If they study they will / would pass ).

(d) Mbudzi ya xela [ ho ngo li vhona ].

( If the goat is lost he will be in for it ).

These sentences 2 (a- d ) indicate that the events will take place in the future and the future tense morpheme **do** is absent

### 3. THE MORPHOLOGICAL STRUCTURE OF THE FUTURE TENSE

The morphological structure of the future tense can be dealt with by studying the following cases:

#### 3.1. THE PARTICIPIAL

(3) (a) Mutukana [ a **tshi do** vhona] vhanwe u **do** shavha.

( The boy will run while he ( will) see the others).

(b) U **nwala** [ a **tshi do** tamba ].

( He will cry while he writes ).

The future tense morpheme ( **do** ) denotes the future tense in sentences 3 (a - b).

The structure will be as follows: [ AGRS – tshi – **do** – V – a ]:

(4) (a) Ndi swika [ a **tshi** guda ] mbalo.

( She learns mathematics while I arrived ).



- (b) Ni mu vhudze [ a **tshi** <sup>^</sup>da ] madekwana.  
 ( Tell him while he comes tonight.

The present tense clause and the participial clause combine to form the future tense in 4 (a - b ). The participial structure in the future tense may be represented as [ AGRS – tshi – V – a ].

### 3.2. THE POTENTIAL

The potential is a mood which expresses ability, or capacity, or possibility. Poulos (1990: 275) notes the following in his discussion of the potential:

The potential is a verb form that is used to express certain significances. The potential may be used to indicate that the subject of the verb has permission to carry out the action denoted by the basic verb root.

- (5) (a) Ndi **nga** <sup>^</sup>da nae matshelo.  
 ( I may come with him tomorrow ).
- (b) Hu **nga** vha na munyanya vhege i <sup>^</sup>daho.  
 ( There is going to be the wedding next week or the wedding is going to be there next week).
- ( c ) A **nga** vha ene khosi i shaho.  
 ( He is going to be a king next year ).

The potential **nga** denotes the present but in this case it is referring to the future tense. The morphological structure of the potential in 5 (a – c) will be represented as [ AGRS – nga – V – a ]:

- (6) (a) Ri **nga** <sup>^</sup>**do** shavha <sup>^</sup>mapfene.  
 ( We may run from the baboons ).
- (b) Ndi **nga** <sup>^</sup>**do** <sup>^</sup>la vhuswa.  
 ( I may eat porridge ).

The future potential structure may be represented as [ AGRS – nga – do – V – a ] in the above sentences 6( a - b ). The potential morpheme <sup>^</sup>do denotes the future tense without ambiguity.

### 3.3. COPULATIVE

The copulative is a clause which expresses the action and provides the information about the subject or identifies the subject in the sentence:

(7) (a) U takalela [ u **vha** munna ].

( He likes to be a man ).

(b) Vha toda [ u **vha** na vhana].

( He / She likes to have children ).

( c ) [ Muri u **vha** muhulu ] nga murahu ha minwaha minzhi..

( The tree becomes huge after many years ).

(d) A tshi tamba na vhanwe [ u **vha** goñoño].

( While he plays with others he becomes a delinquent).

The copulative clause in the present is used to express the future tense in sentences 7 (a – d).

### 3.4. THE CONSECUTIVE

The consecutive is a mood which depends on other moods , and is also known as dependent mood. It expresses serial actions. Ziervogel et al. ( 1972:103) point out:

The consecutive is a tense which occurs in different moods, e.g. in the subjunctive and the participial moods. On the one hand it expresses consecutive action in the past, and on the other hand it expresses conditional action in the past.

Du Plessis & Madadzhe (1999 : 119 ) promote a similar view:

The consecutive expresses consecutive actions.  
In other words it denotes actions which follow one another in a sequence. This seems to be the most important semantic feature associated with the consecutive mood.

The following examples show the consecutive meaning:

(8) (a) Ndi <sup>^</sup>do <sup>^</sup>da, ndi tshi do vhuya uri ri runge.  
( I will come while I shall come back so that we shall sew ).

(b) Ri <sup>^</sup>do <sup>^</sup>da, ra <sup>^</sup>do kuvha.  
( We shall come and wash ).

Sentences 8( a - b ) are formed by the consecutive clauses to indicate the future tense.

The following sentences below also indicate the future copulative in various forms:

### 1. Coordinated Clauses

(9) (a) Tshi<sup>^</sup>noni tshi a fhufha [ tsha <sup>^</sup>do shavha ].  
( The bird is flying and it will escape ).

(b) Mu Kegulu u a wa [ a <sup>^</sup>do huvhala ].  
( The old lady is falling and she will be injured ).

The coordinated clauses of the consecutive mood are attached to the present tense to indicate the future meaning in sentences 9 (a - b).

### 2. Relative Clauses with [ -ne ] in Comp.

(10) (a) Musidzana **ane** [ a <sup>^</sup>do imba ] o swika.

( The girl that will sing arrived ).

(b) Vhuswa **vhune** [ ha **do** bikwa ] ndi v<sup>h</sup>utuku.

( The porridge which will be cooked is very less ).

The complement morpheme **-ne** is attached to the AGRS to form the complement which joins the subject together with the future clause to confirm the future tense in sentences 10( a - b ).

### 3. With [ arali ] as head

(11) (a) Arali n̄wana a **do** fhola ri **do** da  
( If the child is healed we shall come )

(b) Arali nda vhuya u **do** ja vhuswa  
( If I come back he /she will eat the porridge ).

The above sentences 11( a - b ) with **arali** as the head and the future morpheme **do** show the future tense.

### 3.5. URI – CLAUSE / SUBJUNCTIVE

The subjunctive is the dependent mood. Sentences are joined together by the complementizer **uri** to form the subjunctive mood.

Ziervogel et al. (1961 :102 ) define the subjunctive as follows:

The subjunctive which is a dependent mood, indicates that an action must take place or may take place; consequently the conjunction “uri “so that, in , order that is often used.

In this regard Rankhododo (1999 : 322) also indicates:

The subjunctive subordinate clause can be incorporated into either an imperative or

indicative main clause . The subjunctive may be expressed in the positive and negative forms.

(12) (a) U imba **uri** ri **do** tshina.  
          ( He sings so that we shall dance ).

(b) **Ńwana** u lila **uri** vha **do** mu fha.  
          ( The child cries so that they will give him ).

The imperative or indicative main clause and the subjunctive subordinate clause are joined together by the complementizer **uri** to form the subjunctive or the “uri” – clause in the future tense.

### 3.6. LOCATIVE

(13). (a) Ni **do** dzula **murahu** .  
          ( You will sit at the back ).

(b) U **do** dzula **Lwamondo** .  
          ( He will at Lwamondo ).

The locative can be added to the future action in order to indicate where the action will be taking place as in 13 (a - b).

### 3.7. RELATIVE WITH THE RELATIVE MARKER [ - HO ]

(14) (a) **Ńwana** a **do** lwalaho ndi wanga.  
          ( The child who will be sick is mine ).

(b) Ndi mbudzi ine ya **do** laho mavhele.  
          ( It is the goat which will eat mealies ).

The relative morpheme **-ho** is added to the verb roots ( **lwal-** , **l-**) to form the relative ( **lwalaho** , **laho** ) which work together with the future morpheme **do** to indicate the future tense in sentences 14( a - b ).

### 3.8. INTERROGATIVE

- (15) (a) Ni <sup>^</sup>do renga lini?  
 ( When will you buy ? ).
- (b) Vha <sup>^</sup>do dzula ngafhi?  
 ( Where will you live ? ).
- (c) Ndi mini tshine tsha <sup>^</sup>do tswiwa?  
 ( What will be stolen? ).

The interrogative morphemes (-ni? -fhi?) in sentences 15 (a – c ) are used to form the interrogative ( lini? ngafhi? mini?) in the future tense.

### 3.9. INTRANSITIVES

- (16) (a) Mbudzi i <sup>^</sup>do lila.  
 ( The goat will bleat ).
- (b) Tshikolo tshi <sup>^</sup>do vala.  
 ( The school will close ).

The morphological structure of the intransitive in sentences 16 (a - b) may be represented as follows to form the future tense:

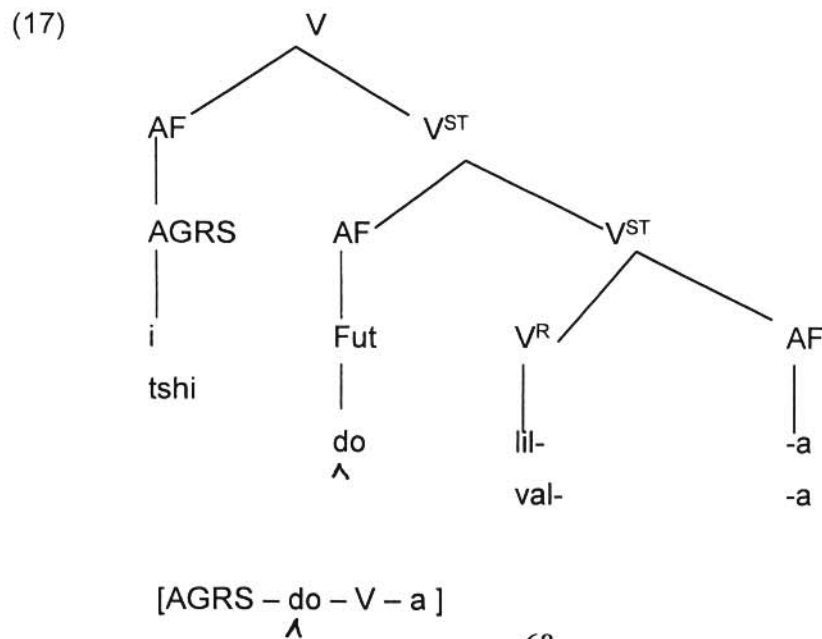

### 3.10. TRANSITIVES

(18) (a) Nwana u <sup>^</sup>do vhala bugu.  
 ( The child will read the bugu ).

(b) Mutukana u <sup>^</sup>do rema muri.  
 ( The boy will chop the tree ).

The future tense is made up of the subject agreement **u** , the future morpheme <sup>^</sup>**do** and the transitive verbs ( **vhala**, **rema** ) in sentences 18( a - b ). The structure can be shown as follows:

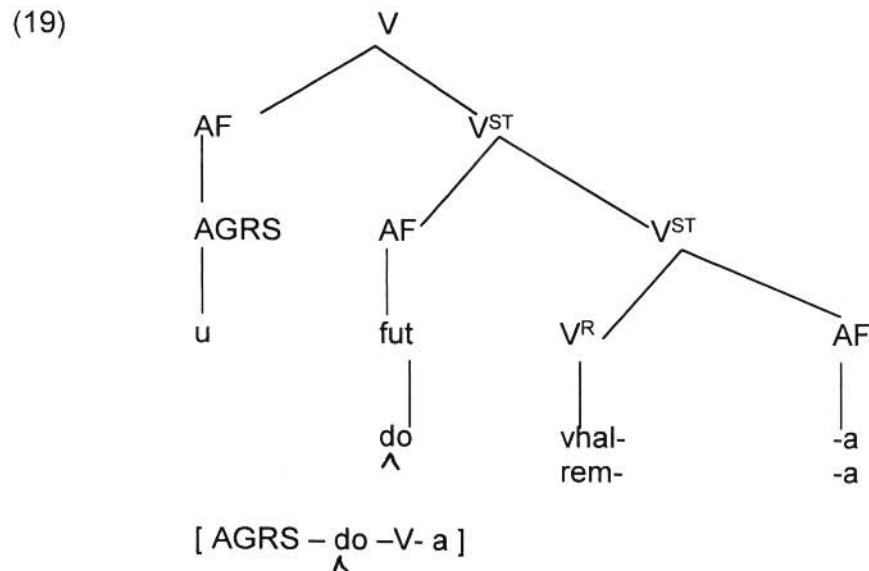

### 3.11. TRANSITIVE WITH [ AGRO ]

(20) (a) Munna u <sup>^</sup>do u rema ( muri ).  
 \* ( The man will chop it the tree ).

(b) Vha <sup>^</sup>do tshi vhulaha tshimange.  
 \* ( They will kill it the cat ).

The future tense in sentences 20 (a-b ) is characterized by the subject agreements (**u** , **vha** ), the future morpheme <sup>^</sup>**do** , the object agreements (**u**, **tshi** ) and the transitive verbs ( **rema**, **vhulaha** ). The morphological structure of the future agreement verbs with the object agreement may be represented as follows:

(21)

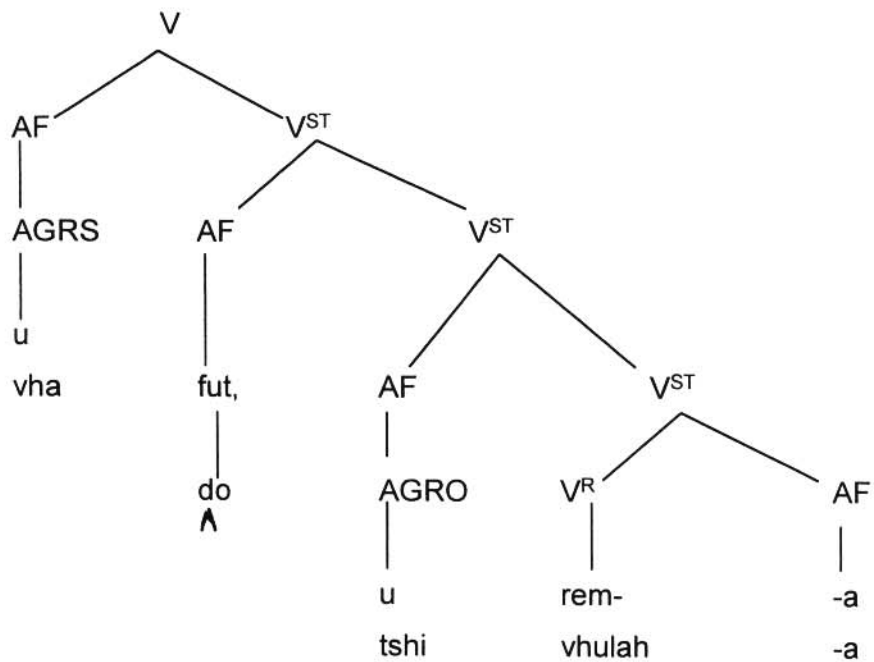

[ AGRS - do - AGRO - V - a ]

### 3.12. NEGATIVE

(22) (a) Nwana **ha nga do** la vhuswa.  
( The girl will not eat porridge ).

(b) Mvula **a i nga do** na.  
( The rain will not fall ).

The sentences in 22( a - b ) are made up of the negative morphemes ( **ha, a, nga** ), the future morpheme **do** and the verbs ( **la, na** ) in the future tense. The morphological structure in the negative in the future tense would look like this:

[ AGRS - Neg - do - v - a ].

### 3.13. INVERSION

(23). (a) (i) Mbudzi i **do** lila .  
( The goat will bleat ).

(ii) Hu **do** lila mbudzi.  
( There will the goat bleat ).



(b) (i) Mulilo u <sup>^</sup>do vhaswa.  
( The fire will be made ).

(ii) Hu <sup>^</sup>do vhaswa mulilo.  
( There will the fire be kindled made ).

( c ) (i) Vhuswa vhu <sup>^</sup>do bikiwa.  
( The porridge will be cooked ).

(ii) Hu <sup>^</sup>do bikiwa vhuswa.  
( There will the porridge be cooked ).

( d ) (i) <sup>^</sup>Nwana u <sup>^</sup>do <sup>^</sup>da matshelo.  
( The child will come tomorrow ).

(ii) Hu <sup>^</sup>do <sup>^</sup>da <sup>^</sup>nwana matshelo.  
( There will the child come tomorrow ).

The subjects move from one position to another in the future tense in sentences 23 (a – d )

#### 4. SEMANTIC SIGNIFICANCE OF THE FUTURE TENSE.

The future tense expresses several meanings. The most important meanings in Tshivenda will be discussed below:

##### 4.1. SIMPLE PRESENT TENSE

###### 1. The use of the simple present tense confirms that activities will take place in the future:

(24) (a) Vha wana ni tshi tamba vha nga ni rwa.  
( If he finds you playing he may beat you ).

(b) Khamusi vha nga <sup>^</sup>tuwa ( vhege i <sup>^</sup>daho ).  
( Perhaps she may go ( next week )

(c) Na <sup>^</sup>tavhanya ni nga mu wana.  
( If you are fast you may find him ).

(d) U thoma u <sup>•</sup>nwala matshelo.  
( He / She starts to write tomorrow ).

(e) Hu dzudzanywa u vula vhengele matshelo.  
( It is planned for the shop to open tomorrow ).

## 2. The simple present tense is used to give directions.

(25) (a) [ Ni bve nga **mulamboni**] ni <sup>^</sup>do mu wana.  
( Go through the river you will find him ).

(b) [ Na dzula kha **tshanda tsha u la** ni <sup>^</sup>do rengeliwa.  
( If you sit on the right hand side they will buy for you ).

(c) [ Ra vhala **heila** bugu ] a u nga <sup>^</sup>kondi.  
( If we read that book it will not be difficult ).

The function of the above sentences may be referred to as the deictic expression of the demonstratives and locatives.

## 4.2. FUTURE AND HABITUAL ACTIONS

(26) (a) Zwinoni zwi <sup>^</sup>do <sup>^</sup>fhata <sup>^</sup>zwitaha.  
( Birds will build nests ).

(b) Vhathu vha <sup>^</sup>do <sup>•</sup>nwala.  
( People will write ).

(c) Tshilimo tshi <sup>^</sup>do <sup>^</sup>da.  
( Summer will come ).

(d) U <sup>^</sup>do dzhena tshikolo.  
( She will attend the school ).

(f) Vha <sup>^</sup>do bika vhuswa tshitangani.  
( She will cook the porridge in the kitchen ).

The habitual actions as indicated in sentences 26 (a – e) will occur in the future tense.

#### 4.3. STATUS

(27) (a) Nwananga u <sup>^</sup>do vha na minwaha ya 12 n'wakani.  
( My child will be 12 years old next year ).

(b) Milayo i <sup>^</sup>do kombetshedza magevhenga u fariwa ( uri vha fariwe ).  
( The laws will compel the thieves to be prisoned ).

( c) Na shavha ni <sup>^</sup>do pandeliwa mushumoni.  
( If you abscond you will be expelled from the job ).

Sentences 27( a- c ) express the future time.

#### 4.4. VOLITION ,WILLINGNESS, OR INTENTION

The volitional meanings of <sup>^</sup>do embrace three subsenses ; i.e. intention , willingness and insistence Hoye ( 1997 : 119 ) argues:

But it is mostly when they have the meaning of willingness, and are used to make requests and offers, that adverb combinations are significant, and particularly in formulaic expressions with “ please “ or “ kindly” , which mark the utterance as a request.

The following sentences indicate volition, willingness or intention:

(28) (a) Ndi <sup>^</sup>do <sup>^</sup>da zwenezwino.

( I will definitely come very soon ).

(b) Ndi humbela uri ni <sup>^</sup>do <sup>^</sup>tuwa <sup>^</sup>rothe?

( Please may / will you go together with me?)

( c ) Arali ni tshi vhuya ni <sup>^</sup>do mpfoinela?

( If you come back will you kindly phone me ?)

(d) Ndi <sup>^</sup>do rengisa goloI yanga.

( I will sell my car ).

( e ) Vha <sup>^</sup>do <sup>^</sup>edela nae.

( She will sleep with her ).

With regard to meaning, Thomson and Martinet ( 1990:168 ) state:

When we say that a form expresses future with intention we mean that it expresses a future action which will be undertaken by the speaker in accordance with his wishes.

In English the present continuous tense of the verb “ be going to “ can be used for the immediate or near future, when we wish to emphasize the subject 's intention.

Thomson and Martinet ( 1980 : 171) concur:

The “ be going to “ form expresses the subject's intention to perform a certain future action. This intention is always premeditated and there is usually also the idea that some preparation for the action has already been made. Actions expressed by “ be going to” form are therefore usually considered very likely to be performed, though there is not the same of definite future arrangements that we get from the present continuous.

In Tshivenda only the future morpheme **do** is applied to indicate the future tense instead of "be going" to or sometimes the auxiliary verb **tuwa** may be used together with the future morpheme **do**. Therefore the following points may be noted:

(29) (a) Ndi **do** tangana nae doroboni.  
 Ndi **do** tuwa ndi tshi tangana nae doroboni.  
 ( I am going to meet him in town ).

(b) U **do** vha mudededzi a tshi aluwa.  
 U **do** tuwa a tshi vha mudededzi a tshi aluwa.  
 ( He is going to be a teacher when he grows up ).

(c) Vha **do** ni thusa.  
 Vha **do** tuwa vha tshi thusa.  
 ( He / She is going to help you ).

Sentences 29 (a–c ) express the idea that the action will take place with immediate effect in the future tense.

#### 4.5. CONDITION, TIME AND PURPOSE

The following sentences are in the future tense. In this case they express the meanings of condition , time and purpose.

(30) (a) Musi hu tshi fhisa mvula i **do** na.  
 ( When it is hot the rain will fall down ).

(b) Arali a wa u **do** huvhala.  
 ( If he falls down he will be injured ).

(c) Hu **do** dudela arali duvha lo bva.  
 ( It will be warmer if the sun set ).

#### 4.6. PREDICTION

Prediction expresses the modification of a tentative nature. The meaning tends to be more flexible:

(31) (a) Khamusi vha <sup>^</sup>do vhuya matshelo.  
( May be they will come back tomorrow ).

(b) Khamusi u <sup>^</sup>do dzula nae.  
( Perhaps he will stay with her ).

The above sentences 31( a – b) express probability or certainty as actions that are likely to occur in the future.

#### 4.7. EMPHASIS

(32) (a) U <sup>^</sup>do vhu bika vhuswa.  
(She will cook it the porridge ).

(b) Ri <sup>^</sup>do mu rwa n'wana.  
( We shall beat him the child ).

(c) I <sup>^</sup>do na mvula.  
( It will rain ).,

(d) Ni <sup>^</sup>do u n'wala mulingo.  
( You will write it the examination ).

(e) Vha <sup>^</sup>do ya matshelo.  
( They will go tomorrow ).

#### 4.8. WITH OR WITHOUT A TIME EXPRESSION

The actions in the future tense can signify the meaning with or without the time reference :

(33). (a) Khamusi vha <sup>^</sup>**do** <sup>^</sup>da.  
( Perhaps they will come ).

(b) Ndi fulufhela uri ri <sup>^</sup>**do** swika.  
( I am sure we shall arrive ).

(c) Vha **nga** ri lindela.  
( They will probably wait for us ).

These meanings may also be embraced in the functions of the verb roots as follows :

#### 4.9. STATIVE ROOTS

(34). (a) Munna u <sup>^</sup>**do** penga.  
( He will be mad ).

(b) Ndi <sup>^</sup>**do** vha ni tshi lwala.  
( You will be sick tomorrow ).

Sentences 34 (a – b ) indicate a future entrance into a state ( the verbs **penga** and **lwala** signify this).

#### 4.10. INCHOATIVE ROOTS

(35). (a) <sup>•</sup>Nwana u <sup>^</sup>**do** neta.  
( The child will be tired ).

(b) Vha <sup>^</sup>**do** <sup>^</sup>edela.  
( They will be asleep ).

(c) Ri <sup>^</sup>**do** ambara zwiambaro.  
( We shall put on clothes ).

The inchoatives **neta**, <sup>^</sup>**edela** and **asleep** indicate the process of “becoming” or the entrance into a state in the future tense in 34( a – c ).

#### 4.11. ACTIONAL ROOTS

(36) (a) Ndi <sup>^</sup>do vula vothi.  
( I will open the door ).

(b) Tshikolo tshi <sup>^</sup>do vala.  
( The school will close ).

The action refers to the meaning of the actional verbs **vula** and **vala** used in the future tense as in sentences 36( a – b )

#### 5. CONCLUSION

The future clause in Tshivenda is mainly characterized by the subject agreement, the future morpheme <sup>^</sup>do, sometimes with the object agreement and the verb which ends with the terminating vowel –a. Although the future morpheme <sup>^</sup>do denotes the future tense, there are other forms which indicate the future; i.e. the participial, potential, copulative, consecutive, uri- clause, locative, relative with the relative marker –ho, interrogatives, intransitives, transitives, transitives with the [AGRO], negatives and inversion.

The chapter also discussed a variety of meanings that are expressed by the future tense. The meanings are: habit, status, volition, willingness or intention, condition / time and purpose, prediction and with or without a time expression .The focus is also on the stative, inchoative and actional verb roots which indicate the state in various contexts.

The chapter also treated different types of verbs such as the stative, inchoative and actional verb roots. These verbs indicate the state in which the subject is in various contexts.



## 1. CONCLUSION

The aim of this concluding chapter is to summarise and give the recommendations about the findings of this research study. The study as a whole is concerned about tenses ( i.e. present, past and future tense ) in Tshivenda.

In everyday communication tenses cannot be ignored. When participants communicate they are bound to use tense and interpret it in various ways.

The purpose of the research study has been achieved by viewing some of the works of other scholars, such as Poulos ( 1990), Du Plessis and Madadzhe (1999), Frawley (1992) and Ziervogel, Wentzel and Makuya (1972 ).

Poulos distinguishes the subject agreement morphemes ( subject concords ) from the object agreement morphemes ( object concords ) as the ones that play an important role in denoting the tenses in Tshivenda. He indicates that the object concord is that element of the verb that shows agreement with the object noun:

- (1) **Mutukana o u rema muri wa wa.**  
( The boy chopped the tree down ).

The subject agreement morpheme **-o** shows agreement with the subject noun **mutukana** in the past tense. The object agreement **u** agree with the object noun **muri** in sentence 1 (a) and does play a role in denoting the past tense or any other tenses.

Du Plessis and Madadzhe regard the present tense as the tense that indicates the period of time which is happening now :

- (2) (a) **Mvula i a na fhano.**  
( It rains here ).

(b) Nwana u a lila.

( The boy is crying ).

(c) Vhana vha a vhala bugu .

( The children are reading the book ).

(d) Tshinoni tshi a fhufha.

( The bird is flying ).

Frawley emphasizes the fact that tense sometimes can be determined by using temporal specification.

(3) (a) Ro swika **zwino**.

( We arrived now ).

(b) O dzula **zwino henefho**.

( He sits there now ).

(c) Vho edela **fhano**.

( They sleep (slept) here).

(d) Ro dzula **fhano** zwino.

( We stays here now ).

(e) Vho tatisana **henefha** namusi.

( They compete here today ).

Ziervogel, Wetzel and Makuya showed that the perfect form of the predicate consists of the subject concord ( to which the perfect formation **o** is added ) and the verb stem:

(4) (a) (i) Vhasidzana **vha** tamba bola.

( The girls play the ball ).

(ii) Vhasidzana **vho** tamba bola.

( The girls played the ball ).

(b) (i) Khuhu **dzi** kudzela tshitumbani.

( The hens lay in the nest ).

(ii) Khuhu **dzo** kudzela tshitumbani.

( The hens laid in the nest ).

( c) (i) Zwikolo **zwi** a vala.

( The schools are closing ).

(ii) Zwikolo **zwo** vala.

( The schools closed ).

It has been shown in chapter 3 that the past tense morpheme **-o** changes the subject or object morpheme in the present tense into the subject or object agreement morpheme in the past tense. In sentences 4 (a - c ) the subject agreement morphemes **vha**, **dzi** and **zwi** in the present tense change into **vho**, **dzo** and **zwo** in the past tense.

In this research, intransitive, transitive and ditransitive verbs were employed to show the morphological structure of the present, the past and the future tense. Some of the moods, the interrogative, the negative and inversion also assisted in the construction of the tenses. It has also been indicated that several types of verbs can also appear in the said tenses. The verbs are inchoative, stative and actional in nature.

Chapter 2 provided an extensive survey of the present tense. The present tense consists of the short and long forms:

(5) (a) The short form : U vhona thelevisheni.

( He / She sees a television ).

(b) The long form : U a <sup>^</sup>talela thelevision.

( He / She is watching a television).

The structure and semantic significance of the past tense was dealt with in chapter 3. It has been clearly indicated that the past tense morpheme -o changes the subject or object agreement morpheme in the present tense into the subject or object agreement morpheme in the past tense:

(6) (a) (i) **Vha** mu rwa , **a** lila a vhuya a **na**la.

( They beat him and cries until he loses his temper ).

(ii) **Vho** murwa , **o** lila a vhuya a **na**la.

( They beat him and cried until he loses his temper ).

(b) (i) **Dzi** a xela mbudzi thavhani.

(They are lost the goats in the mountain).

(ii) **Dzo** xela nmbudzi thavhani.

( They were lost the goats in the mountain ).

( c) (i) **A** vhu bika vhuswa **ha** <sup>^</sup>liwa.

\* ( She cooks it the porridge and it has been eaten).

(ii) **O** vhu bika vhuswa **ho** <sup>^</sup>liwa.

\* ( She cooked it the porridge and it had been eaten ).

In chapter 4 the future tense was investigated. It has been shown that the action takes place sometimes in the future. The moods were employed to show the future tense. The participial, potential, copulative and consecutive moods were examined in terms of the form and meaning . The future tense expresses many meanings and the most important are:

- Status
- Volition
- Willingness
- Intention
- Condition
- Time

- Purpose
- Prediction

It was revealed that there is an interrelationship between tenses, therefore the speaker is free to use any tense to convey his message to the recipients:

(7) (a) Muya wo vhudzula vhukuma.

( The wing blows heavily ).

or

( The wind blew heavily ).

(b) Ndo edela.

( I am asleep ) or ( I was asleep ).

( c) "Bafanabafana" yo kora luvhili.

( "Bafanabafana" scores twice ).

or

( "Bafanabafana " scored twice ).

(d) Mvula yo na.

( It rains ) or ( It rained ).

(e) Ro neta.

( We are tired ) or ( We were tired ).

Tenses in Tshivenda are interrelated. It is possible for the past tense to denote the meaning that is generally associated with the present tense . Consider the following examples:

(8) (a) Ndo edela.

( I am asleep ).

(b) Vho neta.

( They are tired ).

It has been discovered that not only the forms of the verbs in Tshivenda determine the tense. There are some grammatical means for locating events in time that denote tense such as adverbs and temporal references. In Tshivenda the tense is denoted mostly by the agreement morphemes and the future tense morpheme **do**:

- (9) (a) U a la.  
           ( She eats ).
- (b) Vha a la.  
           ( They eat ).
- (c) Vho la zwino.  
           ( They eat now ).
- (d) Vho la.  
           ( They ate ).
- (e) Vha do la.  
           ( They will eat ).

Sentences 9 (a – e) denote different tenses in Tshivenda. The study also showed that the verb only cannot denote the tense in Tshivenda. For example, the verb **la** cannot denote the tense in Tshivenda. Sentences 9 (a – c) are in the present tense. The subject agreements **u** and **vha** and the adverb **zwino** denote the present tense. In sentence 9( d) the subject agreement morpheme **vho** indicates the past tense. Sentence 9( e) shows the future tense. The future morpheme **do** signifies the future tense.

In conclusion, the formation of the tenses can be summarized in a table form as follows:

Formative Morphemes	Present Tense	Past Tense	Future Tense
Short form without affix (a)	-	-	-
Long form: affix (a)	+	-	-
AGRS:	+	+	-

AGRO:	+	+	-
do: ^	-	-	+
Potential ( nga)	-	-	+
Copulative (vha)	-	-	+
Negative	+	+	+

## 2. RECOMMENDATIONS

The study suggests the following recommendations:

- Tense as a morphological aspect must not be studied in isolation  
Meaning associated with tense must also be scrutinised
- Tenses in Tshivenda are not necessarily formed by the verb form but by various morphemes.

The study has proved that tenses in Tshivenda express a variety of meanings and these can be illustrated thus:

Meanings	Present Tense	Past Tense	Future Tense
Temporal specification ( place , time, adverb)	+	-	+
Habit	+	-	+
Emphasis	+	+	+
Ongoing Action	+	-	-
Present continuous action	+	-	-
Past tense action	-	+	-
Present tense action	-	+	-
Recent past	-	+	-
Remote past	-	+	-
Status	-	-	+
Volition	-	-	+
Willingness	-	-	+
Intention	-	-	+
Condition	-	-	+
Purpose	-	-	+
Prediction	-	-	+

## REFERENCES

1. Barnes, A.S.V, Hugard, J.H., and Caley, W.B 1967. *Morden Graded English for Secondary Schools*. Johannesburg : Via Afrika
2. Bell, J. 1993. *Doing your Research Project. 2<sup>nd</sup> . ed. A Guide for First – Time Researchers in Education and Social Sciences*.Buckingham: Open University.
3. Cook, Vivian , and Newson, Mark .1996.*Chomsky’s Grammar:An Introduction*. Oxford: Blackwell.
4. Creswell, J.W 1994. *Research Design*.Thousand Oaks : Sage.
5. Du Plessis, J.A. , and Madadzhe ,R.N. 1999.*Venda Morphology*. University of Stellenbosch.
6. Du Plessis , J.A., and Visser, Marianna. 1996. *Venda Syntax*. Department of African Languages. University of Stellenbosch.
7. Elsness, Johan. 1997. *The Perfect and the Preterite in Contemporary and Earlier English*. Berlin, New York: Mouton de Gruyter.
8. Frawley, William, 1992. *Linguistic Semantics. United States of America: Hillsdale, New Jersey: Lawrence Erlbaum Associates ,Publishers*.
9. Gray, L.R. 1996. *Educational Research Competencies for Analysis and Application*. Englewood Cliffs: Merrill.
10. Hopper, J., Paul and Thompson, A., Sandra. 1982. *Syntax and Semantics. Volume 15 . Studies in Transitivity*. New York : London . Academic Press, A subsidiary of Harcourt Brace Jovanovich, Publishers.
11. Horrocks , Geoffrey . 1987. *Generative Grammar* . London and New York: Longman.



12. Hoyer, Leo. 1997. *Adverbs and Modality in English*. London and New York: Longman.
13. Huddleston, Rodney. 1984. *Introduction to the Grammar of English*. New York: Cambridge University Press.
14. Klein, W. 1992. *The Present Perfect Puzzle*. *Language* 68: 525- 552
15. Lyons, John. 1977. *Semantics . vols . 1 –2* Cambridge: Cambridge University Press.
16. Lyons, John. 1981 a. *Language and Linguistics*. Cambridge Cambridge University Press.
17. Lyons, John . 1997 . *Semantics*. Cambridge: Cambridge University Press
18. Madadzhe , R.N. 1997. *The Copulative in Venda* . Unpublished D. Litt. Dissertation. University of Stellenbosch
19. Mc Magh, Patricia . 1970. *English for South Africa* 2<sup>nd</sup> . ed. Cape Town NASOU Limited.
20. Mc Millan, James , H. and Schumacher Sally. 1993. *Research in Education A conceptual Introduction*. Harper Collins, College Publishers.
21. Milubi , N.A. 1996 . *Ngoma ya Vhatei* Pietersburg: NAM Publishers.
22. Poulos , G. 1990. *A Linguistic of Analysis of Venda*. Pretoria . UNISA.
23. Rankhododo, T.K. 1999. *Inflection in Venda*. Unpublished. Dissertation University of Stellenbosch.
24. Sells, Peter. 1985. *Lecturer on Contemporary Syntactic Theories* Center for the study of Language and Information.

25. Thompson , J.A. and Martinet, V.A. 1980. *A Practical English Grammar*, 3<sup>rd</sup> ed . London : Oxford University Press
26. Ziervogel, D. Wentzel, P.J, and Makuya, T.N. 1972. *A Handbook of the Venda Language*: Pretoria: UNISA